

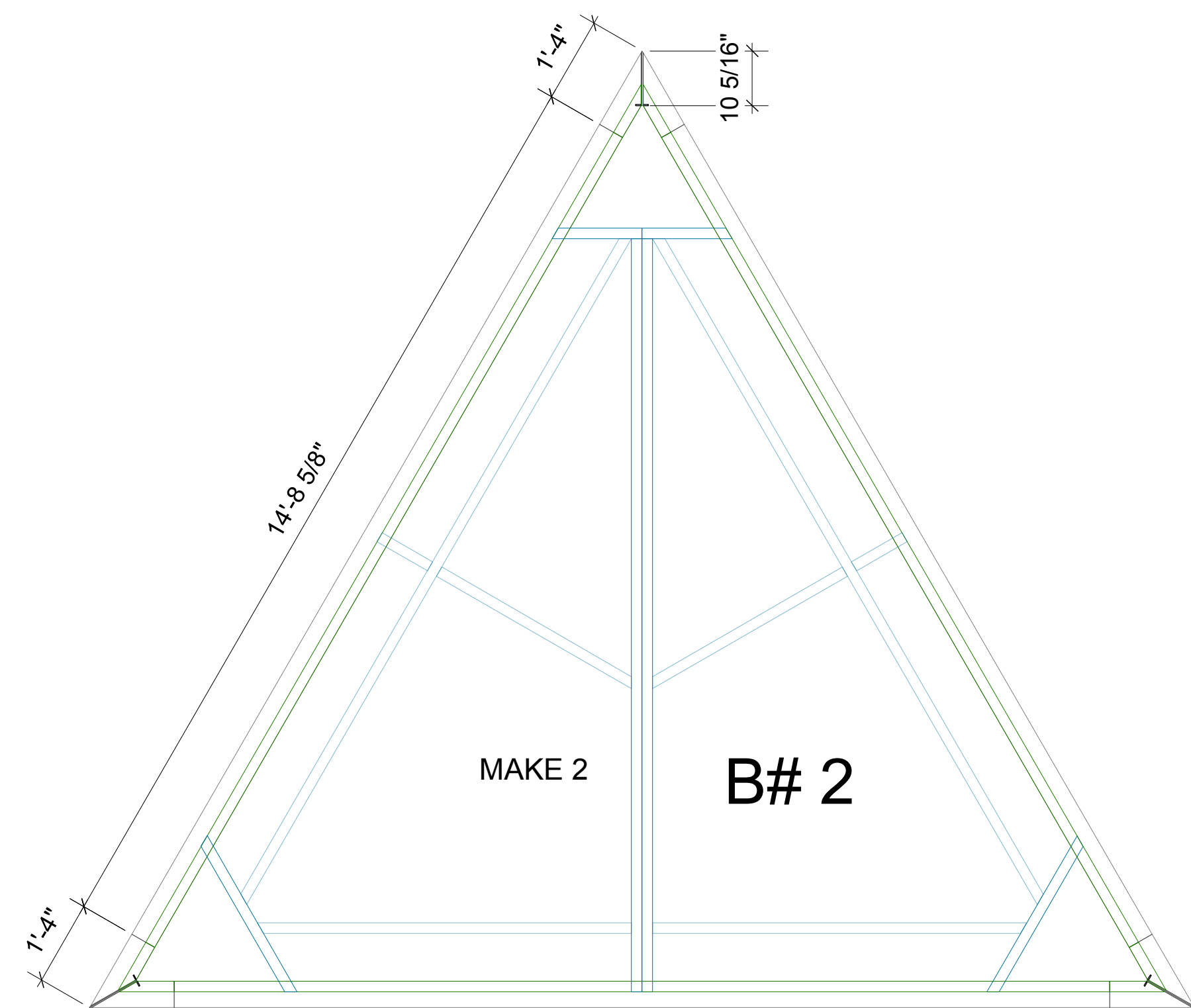

UP  
CLOSE MICHELANGELO'S  
SISTINE CHAPEL

E0000000

\*j

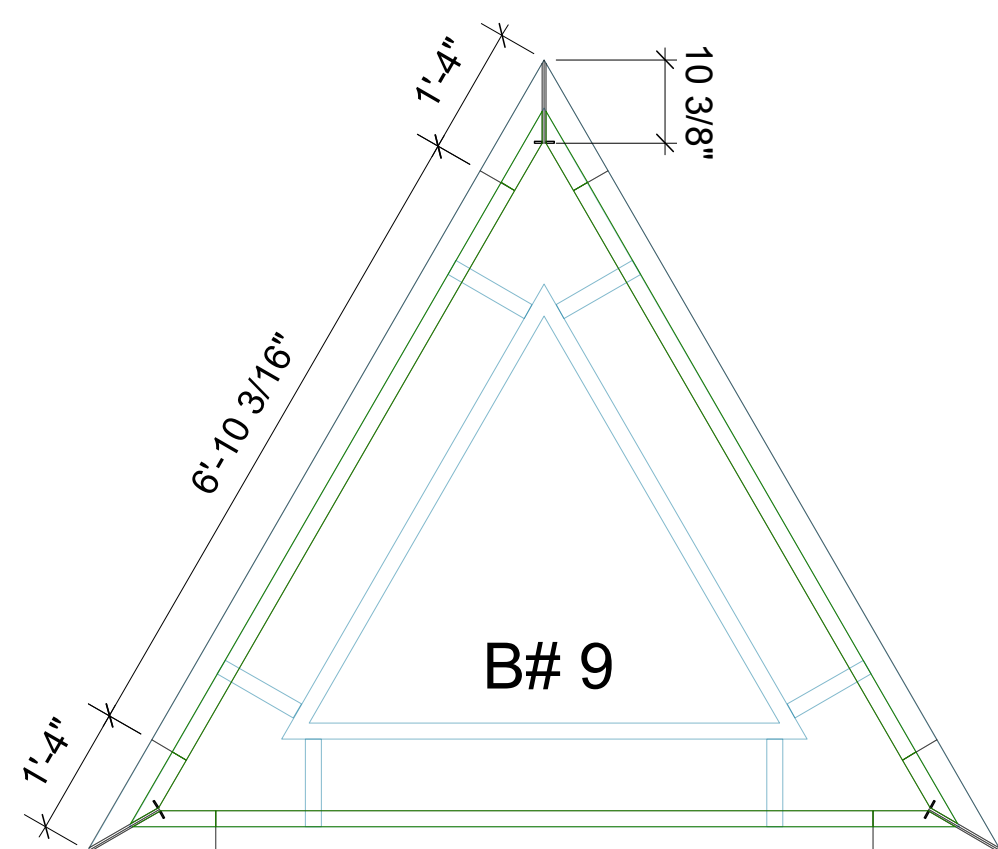
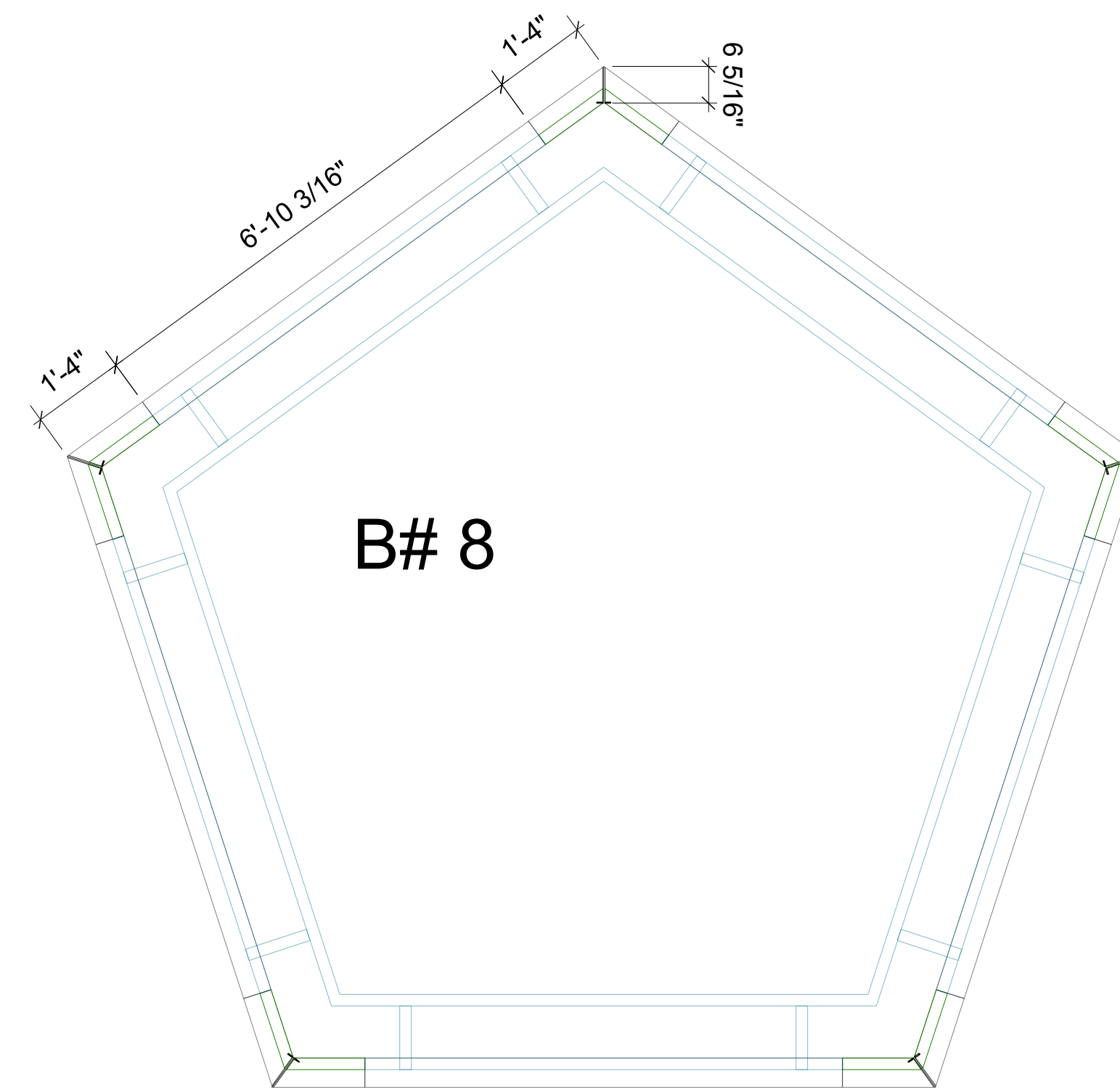
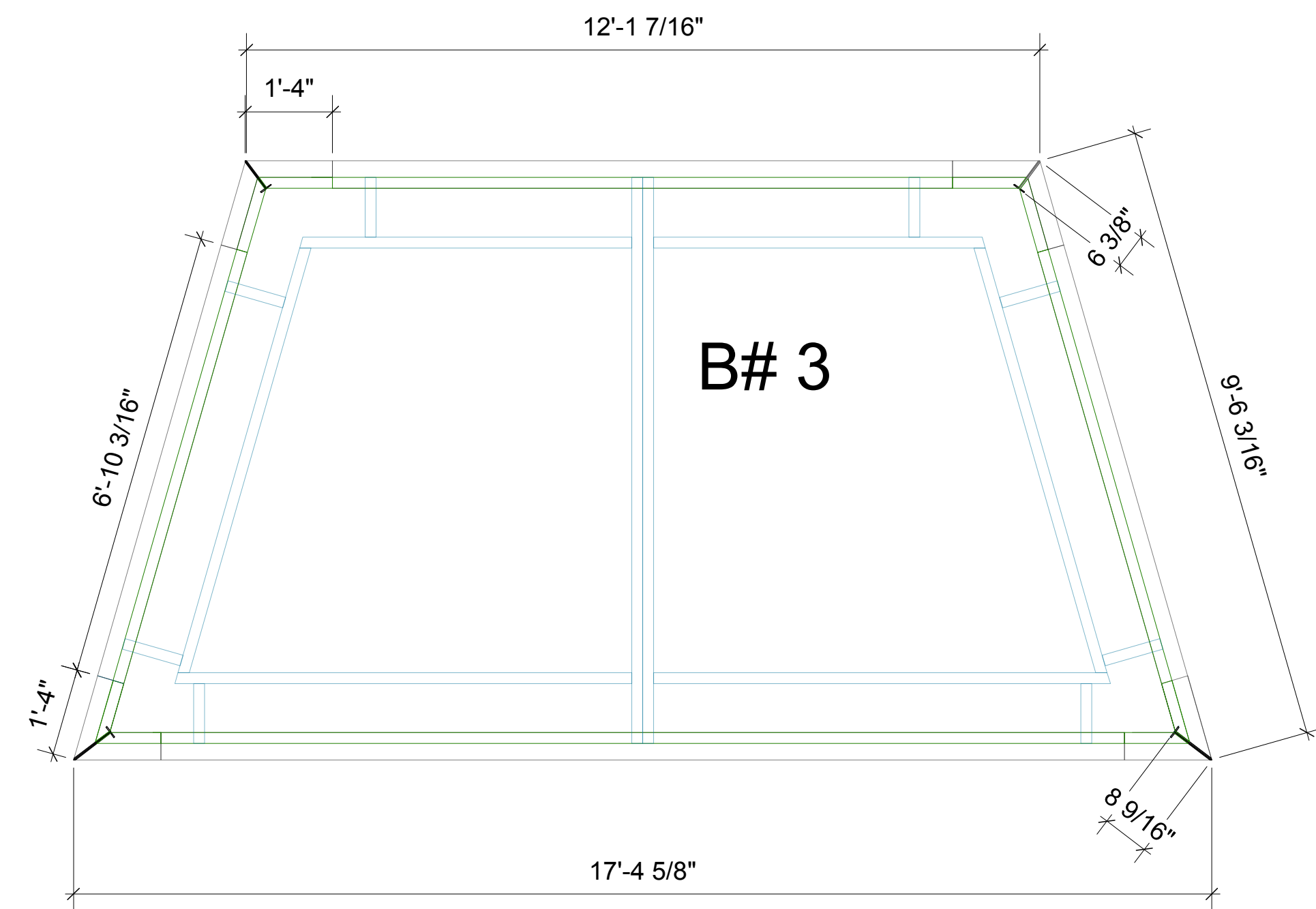
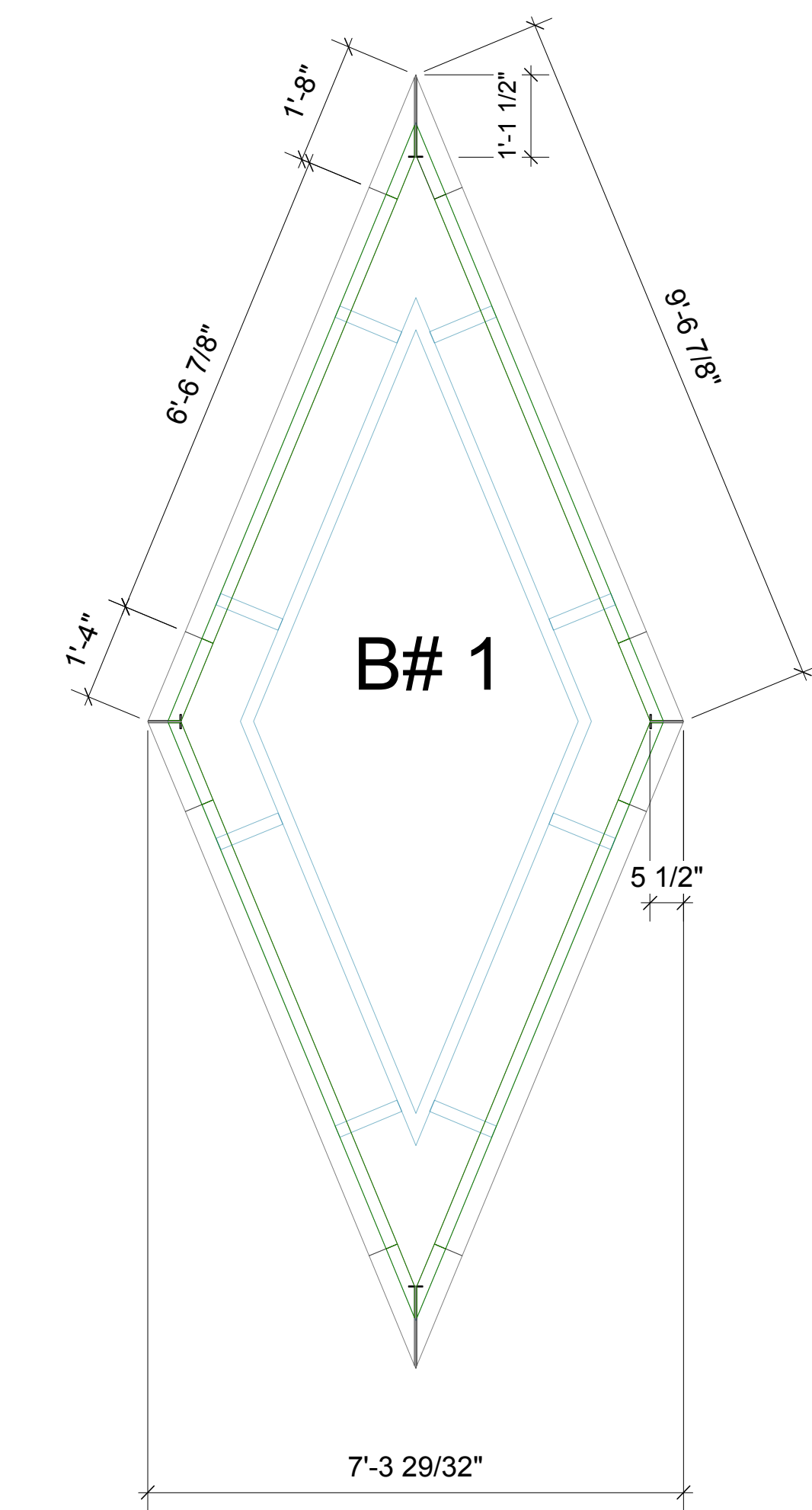

HOLD ON INNER FRAME DETAILS

1 SHAPES PLAN VIEW  
Scale: 1/2" = 1'-0"

Date: 5/26/17  
Time: 12:01:44 PM  
File name: SISTINE\_FRAMES\_PLAN\_VIEW\_5-26-17\_11.25\_AM.vwx

**ATOMIC**  
 ATOMICDESIGNITY  
 P: 717.626.8301  
 F: 717.627.7756  
 10 WYNFIELD DRIVE  
 LITITZ, PA 17543

**RH**  
 RAYMOND H. HARRIS  
 ARCHITECT  
 LEAD

**SISTINE CHAPEL DISPLAY ARCH D**

DATE: 5/26/17  
 SCALE: As noted.  
 PAPER: 24" x 36"

ACCOUNT MANAGER: DOUG FRAWLEY / JOE MCMONAGLE  
 PROJECT MANAGER: KEITH REILLY  
 DRAWING BY: JR

**00.001**  
 ELEMENT DRAWING

CONTACT

PRINT INFO

FILE NAME: SISTINE\_FRAMES\_PLAN\_VIEW\_5-26-17\_11.25\_AM.vwx

COPYRIGHT ATOMIC DESIGN - PLEASE NOTE: THESE DESIGNS AND/OR DRAWINGS ARE A REPRESENTATION ONLY. THE DESIGNER AND/OR DRAFTER PERSON IS NOT QUALIFIED TO DETERMINE WHETHER THE DRAWING AND/OR DESIGN MEETS STRUCTURAL SAFETY AND/OR BUILDING CODE REQUIREMENTS. ANY/FALL ASPECTS OF THIS DRAWING ARE SUBJECT TO CHANGE. ALL DIMENSIONS SCALED OR LISTED ARE APPROXIMATE.

\*j 17034 E0003

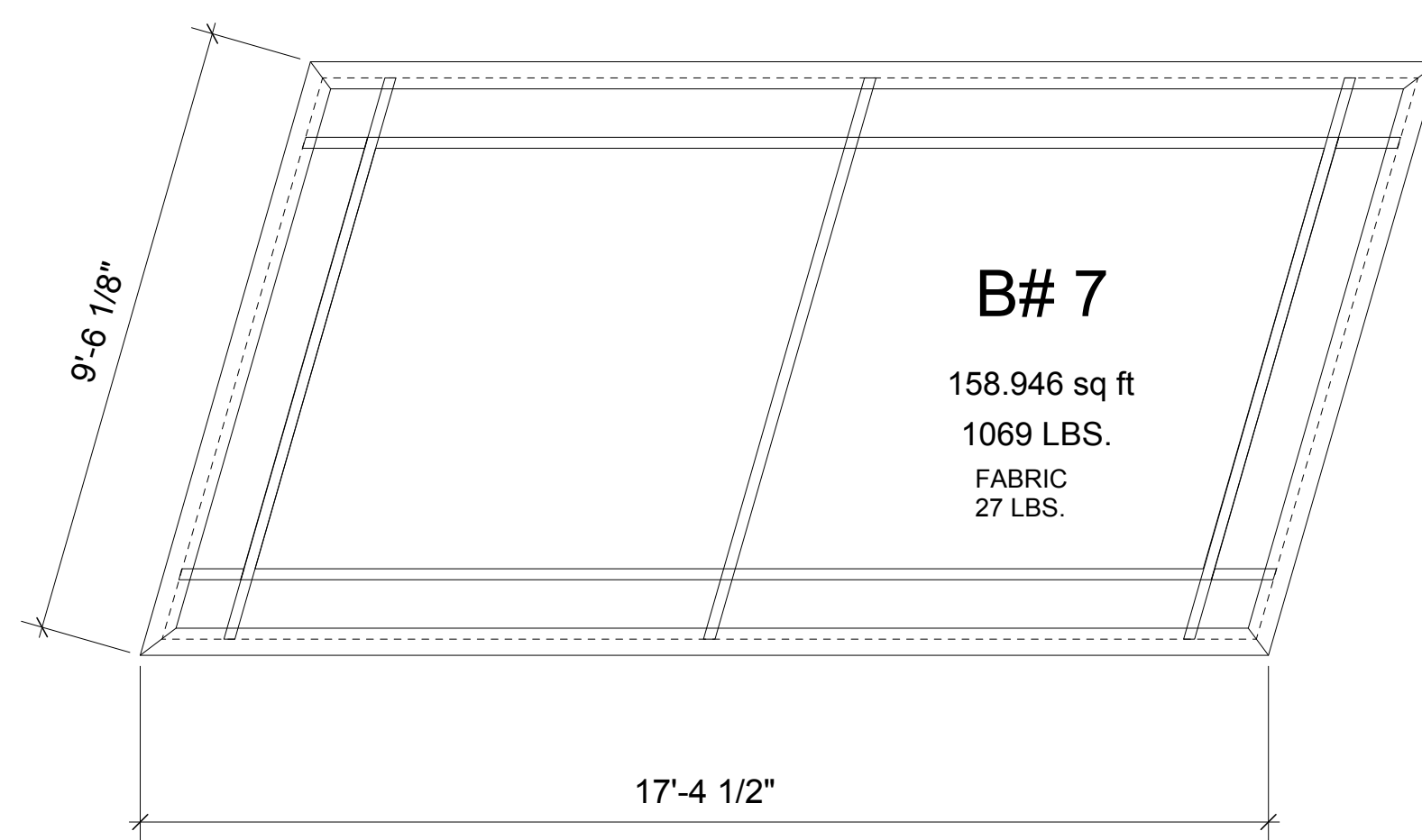
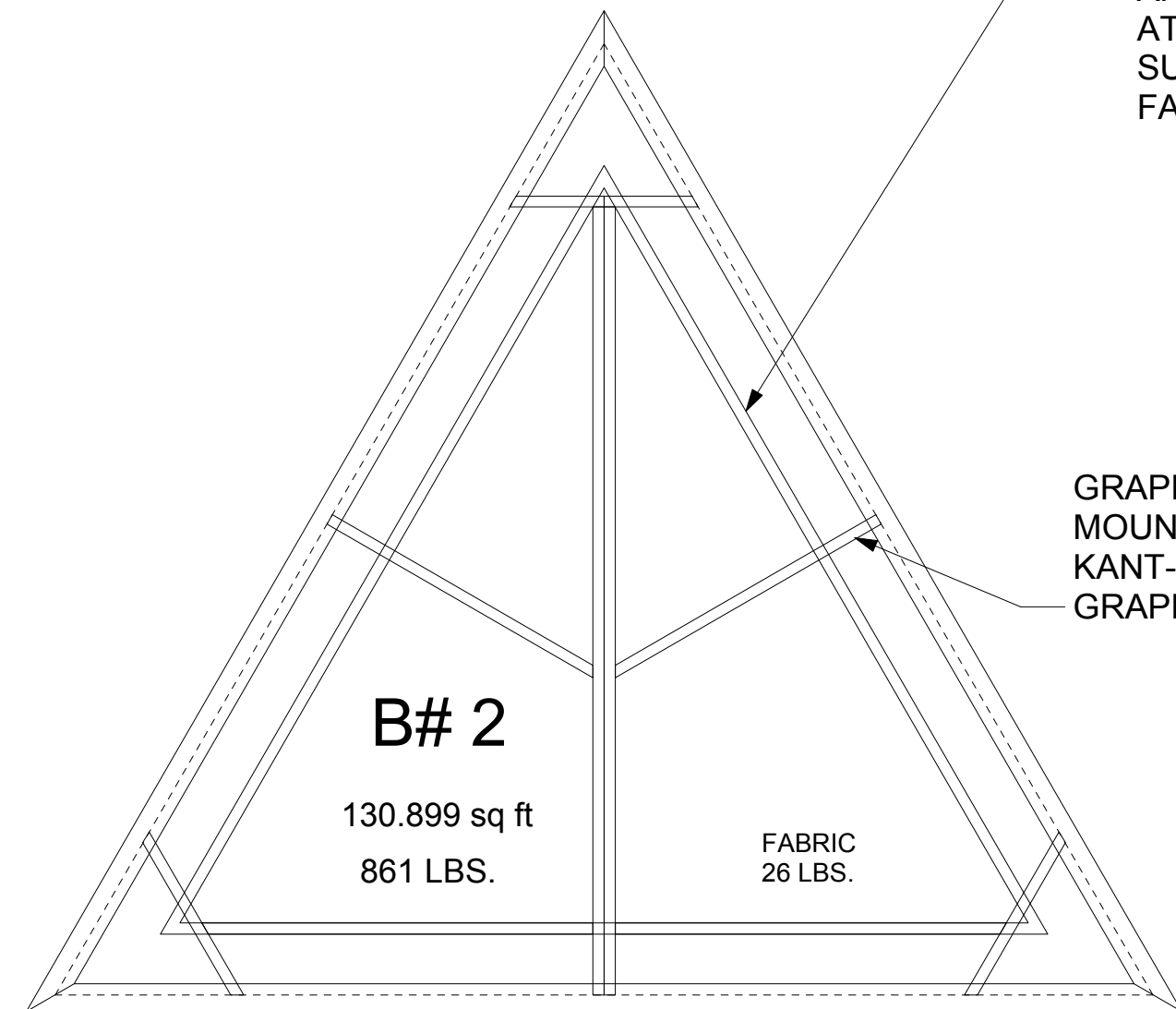
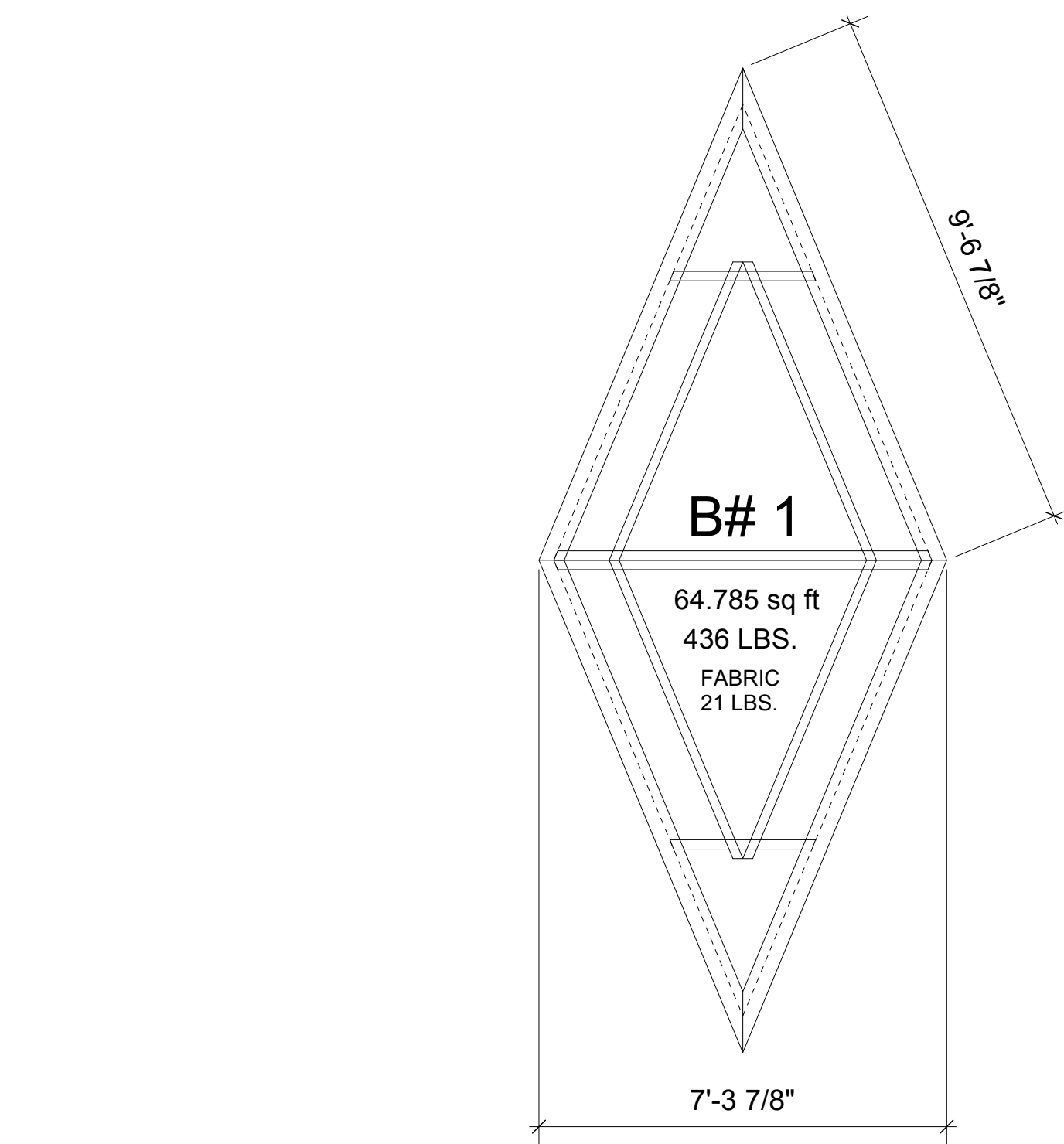

VERTICAL 2 X 2 TUBE  
FRAME PERIMETER  
HOLD LED LIGHTS  
AND SUPPORTS  
ATTACHED  
SUPPORT FOR THE  
FACE FRAME

GRAPHIC FACE FRAME  
MOUNTS TO  
KANT-O-LEVERED TUBE  
GRAPHIP SITS ON FLOOR

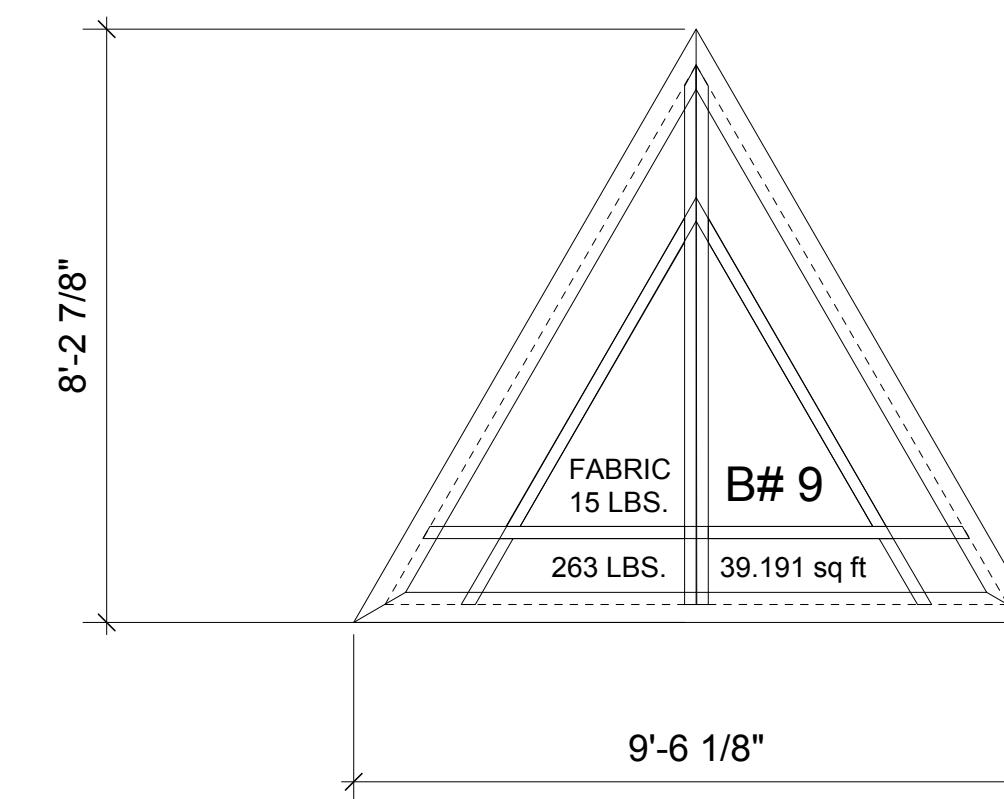
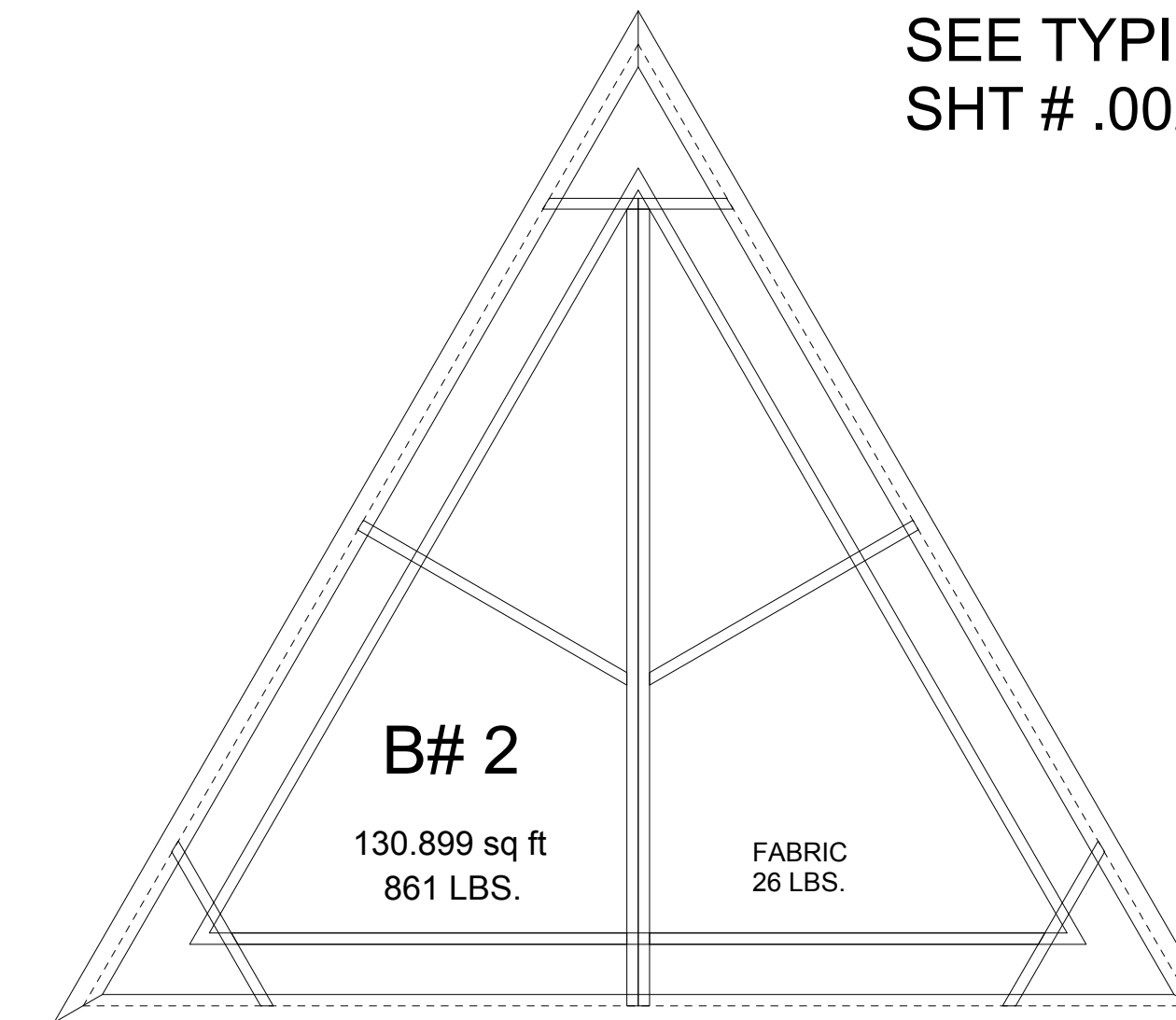
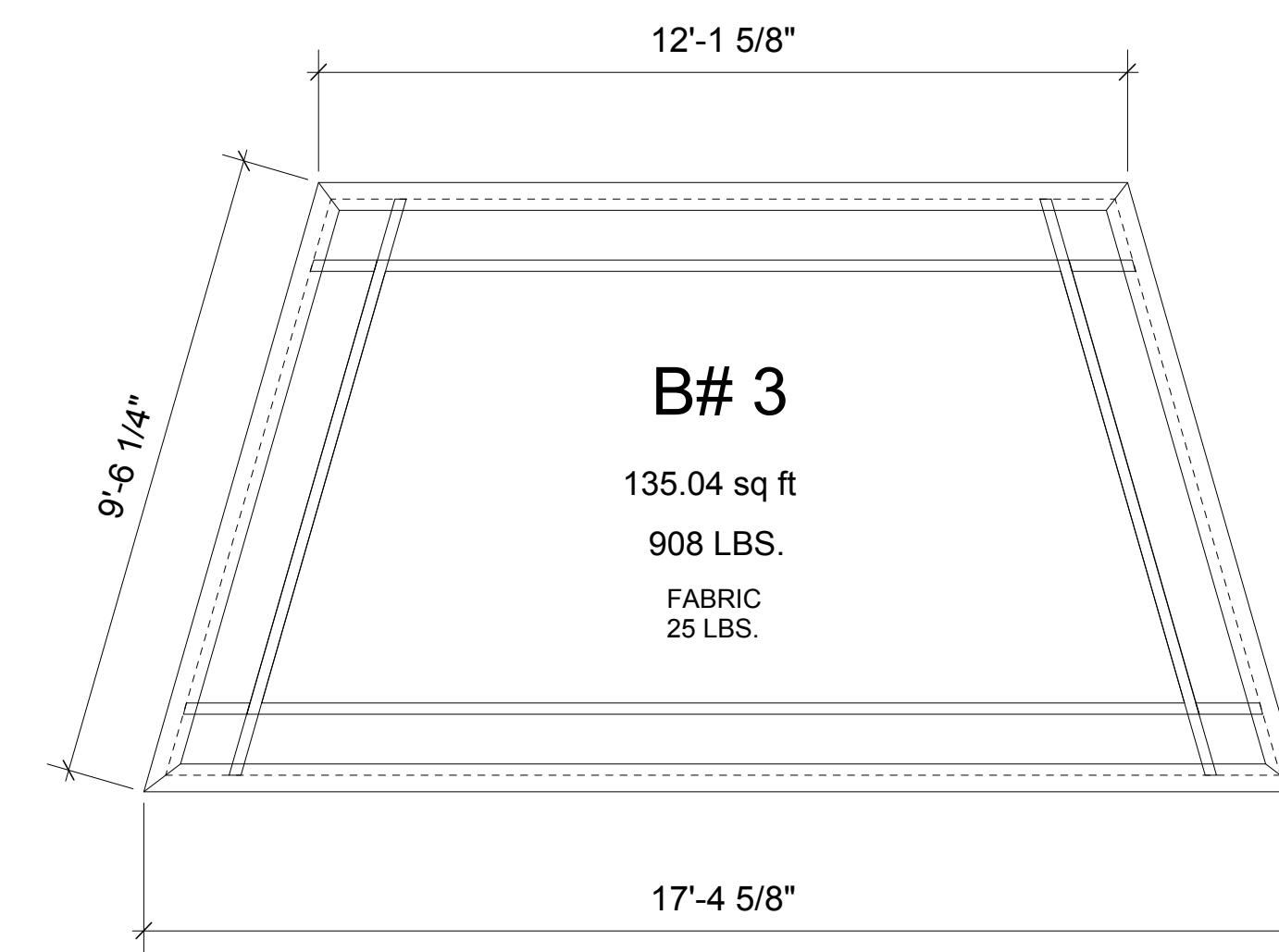
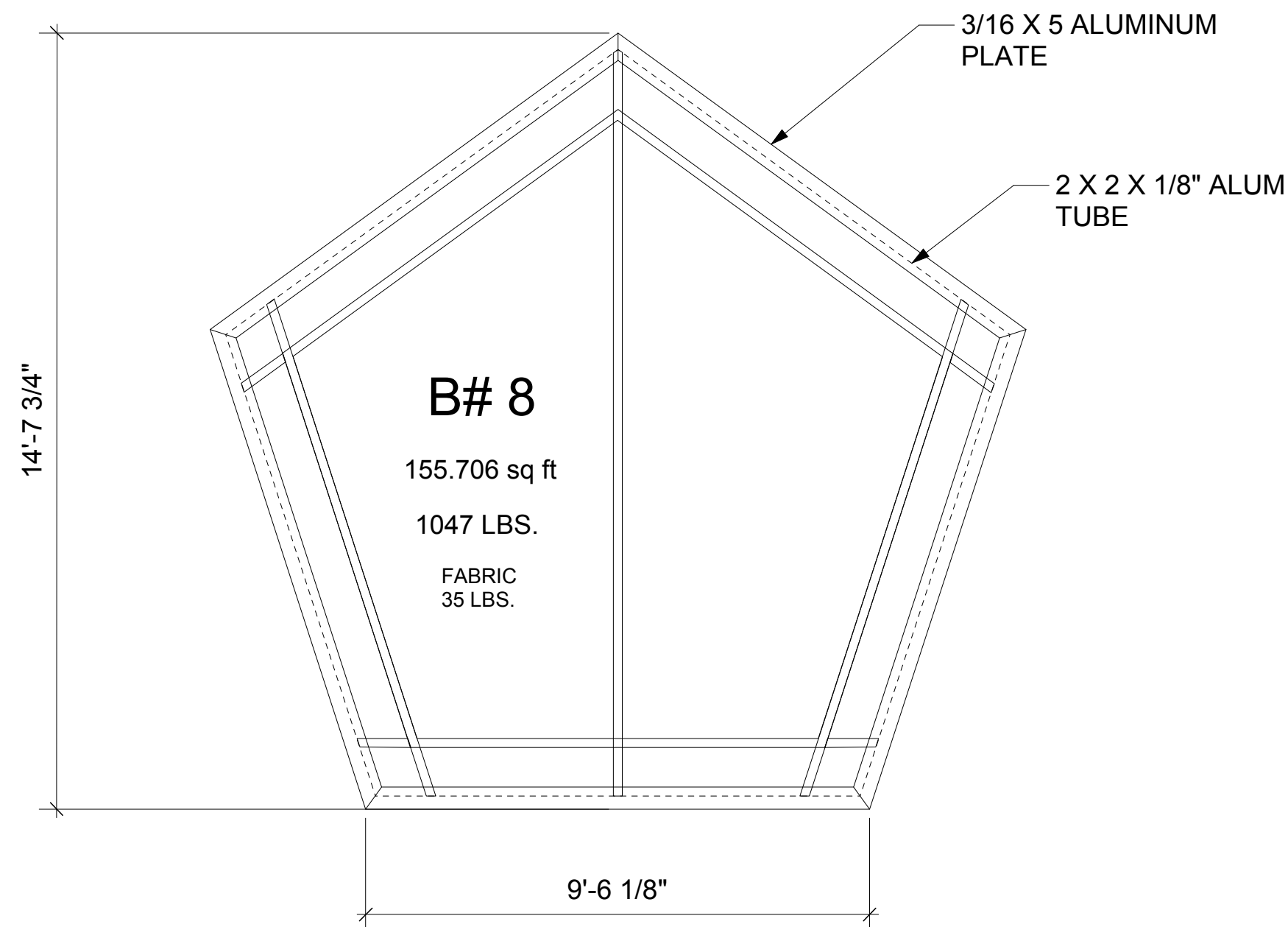
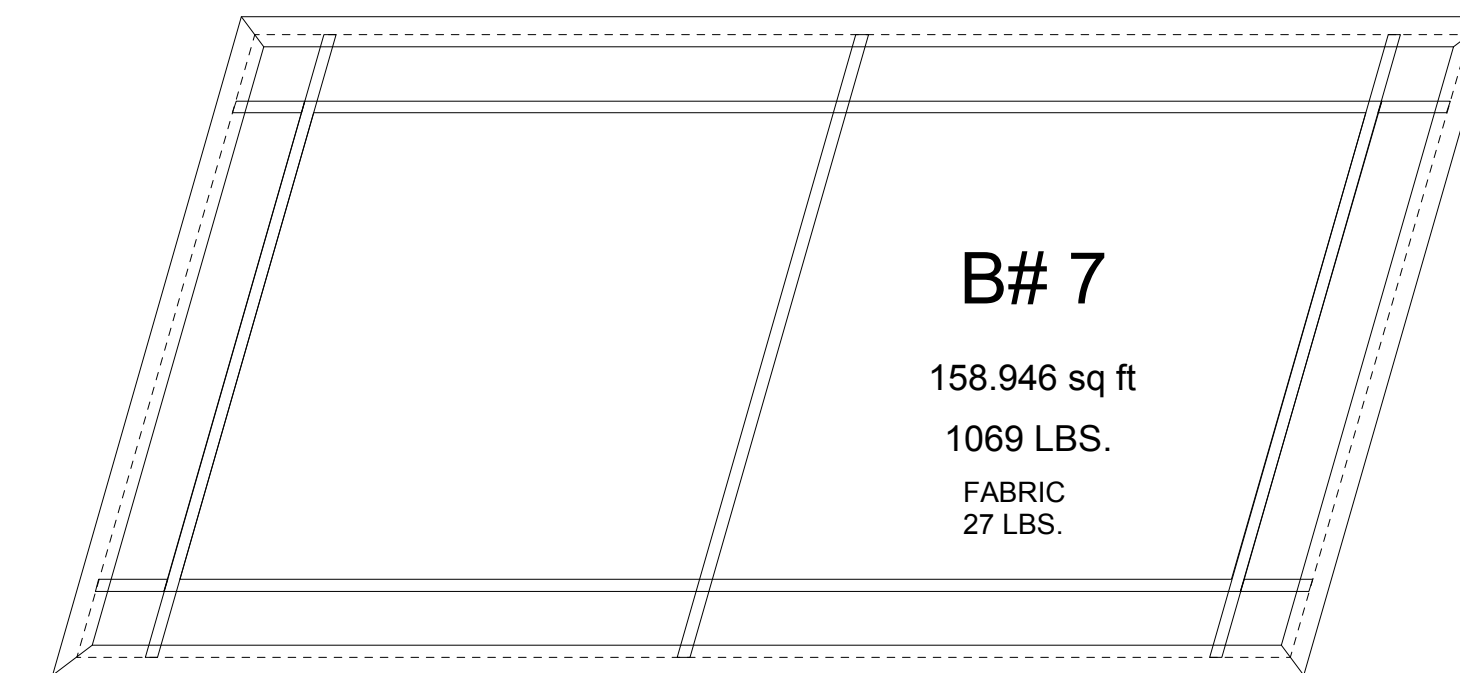
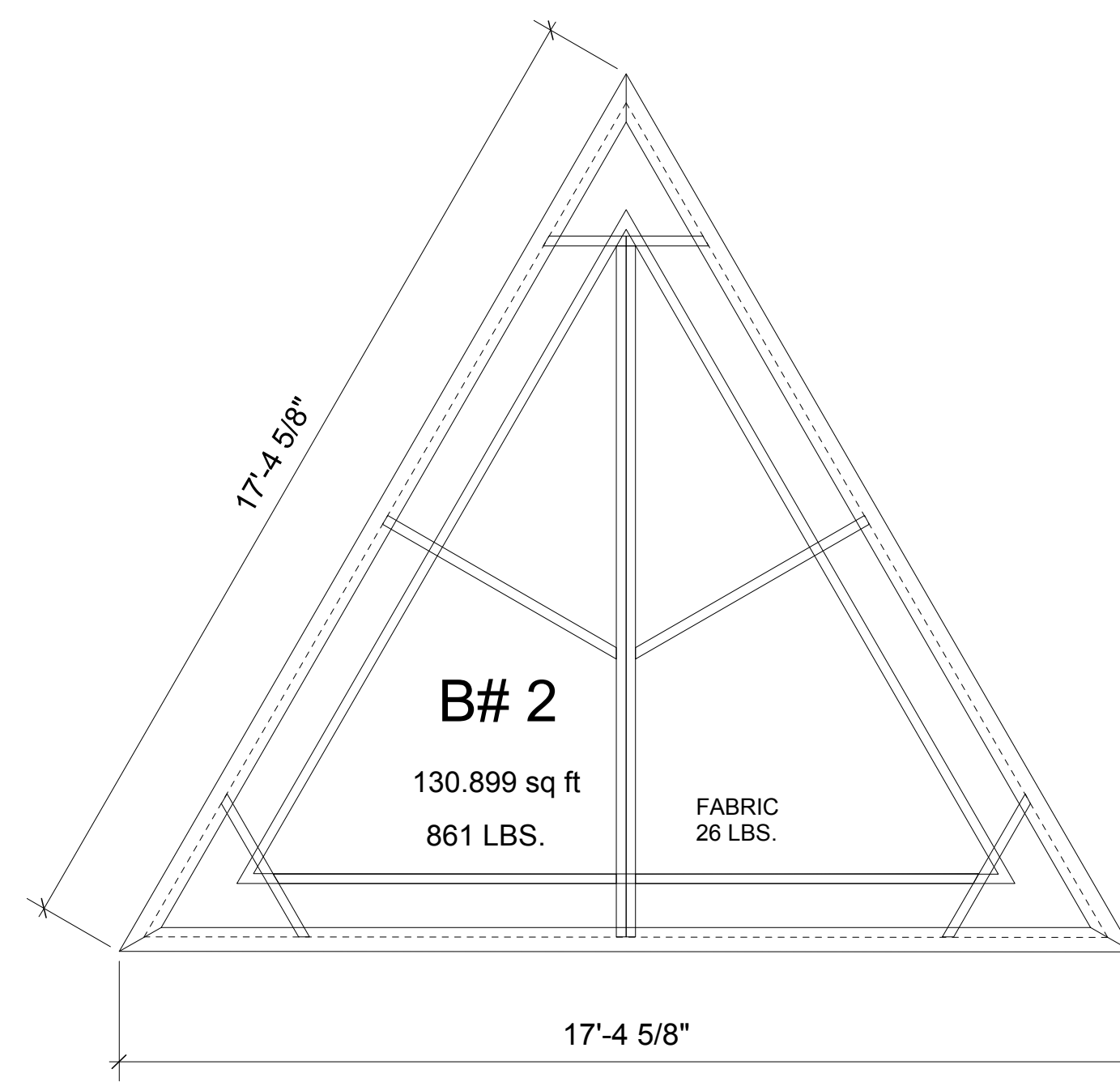

SEE TYPICAL DETAILS  
SHT # .002, .003

1 SHAPES GROUND PLAN  
Scale: 3/8" = 1'-0"

ROBIN HOOD  
ARCH D

00.001  
DRAWING ELEMENT

NUMBER 17034

ATOMIC DESIGN  
P: 717.626.8301  
F: 717.627.7756  
10 WYNFIELD DRIVE  
LITZ, PA 17543

RH  
ROBIN HOOD  
ARCHITECTURE  
LEAD

DATE: 5/12/17  
SCALE: As noted.  
PAPER: 24" x 36"

ACCOUNT MANAGER: DOUG FRAWLEY / JOE MCMONAGLE  
PROJECT MANAGER: STEPHEN A. KAEHLIN  
DRAWING BY:

CONTACT

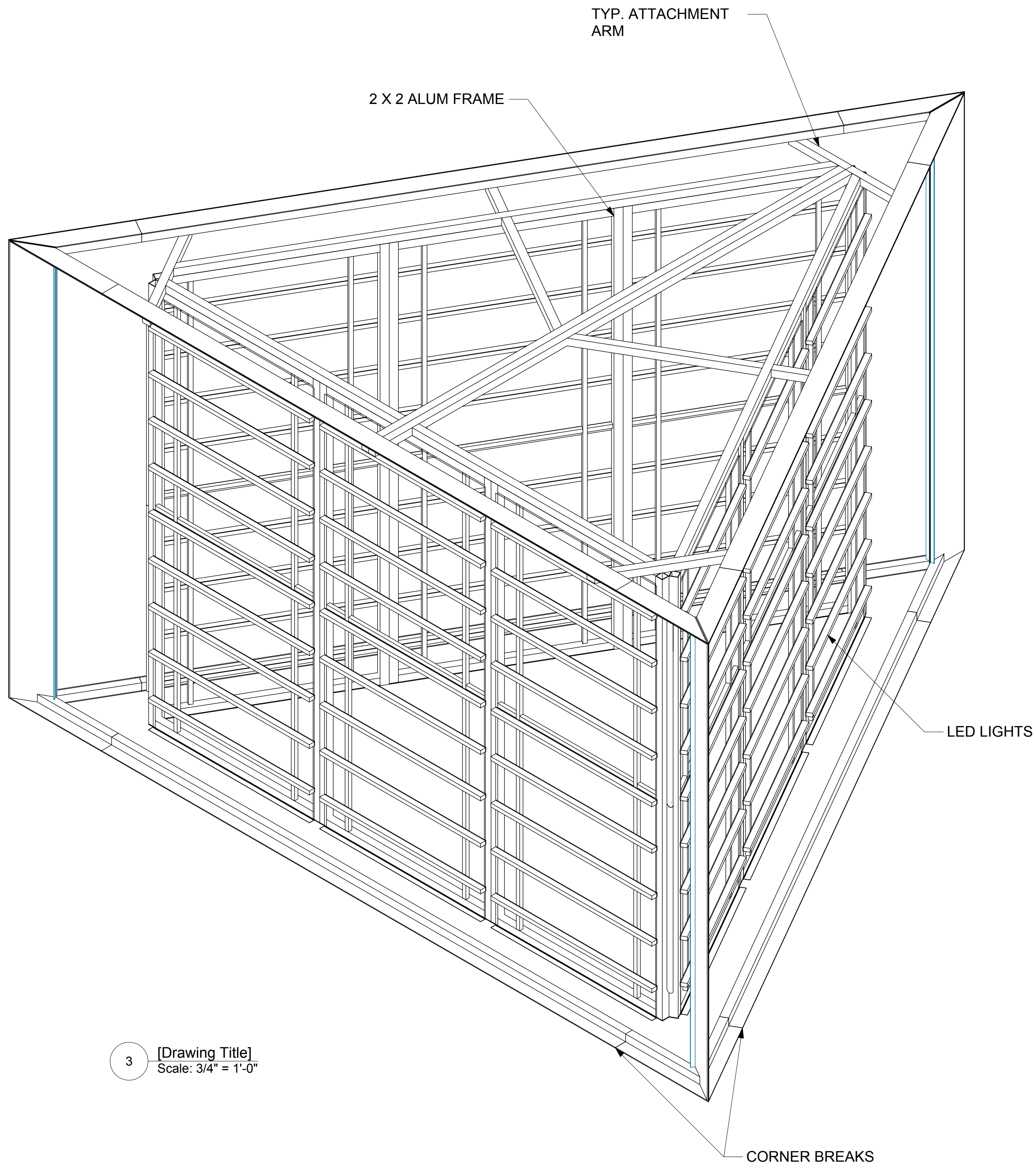

3 [Drawing Title]  
Scale: 3/4" = 1'-0"

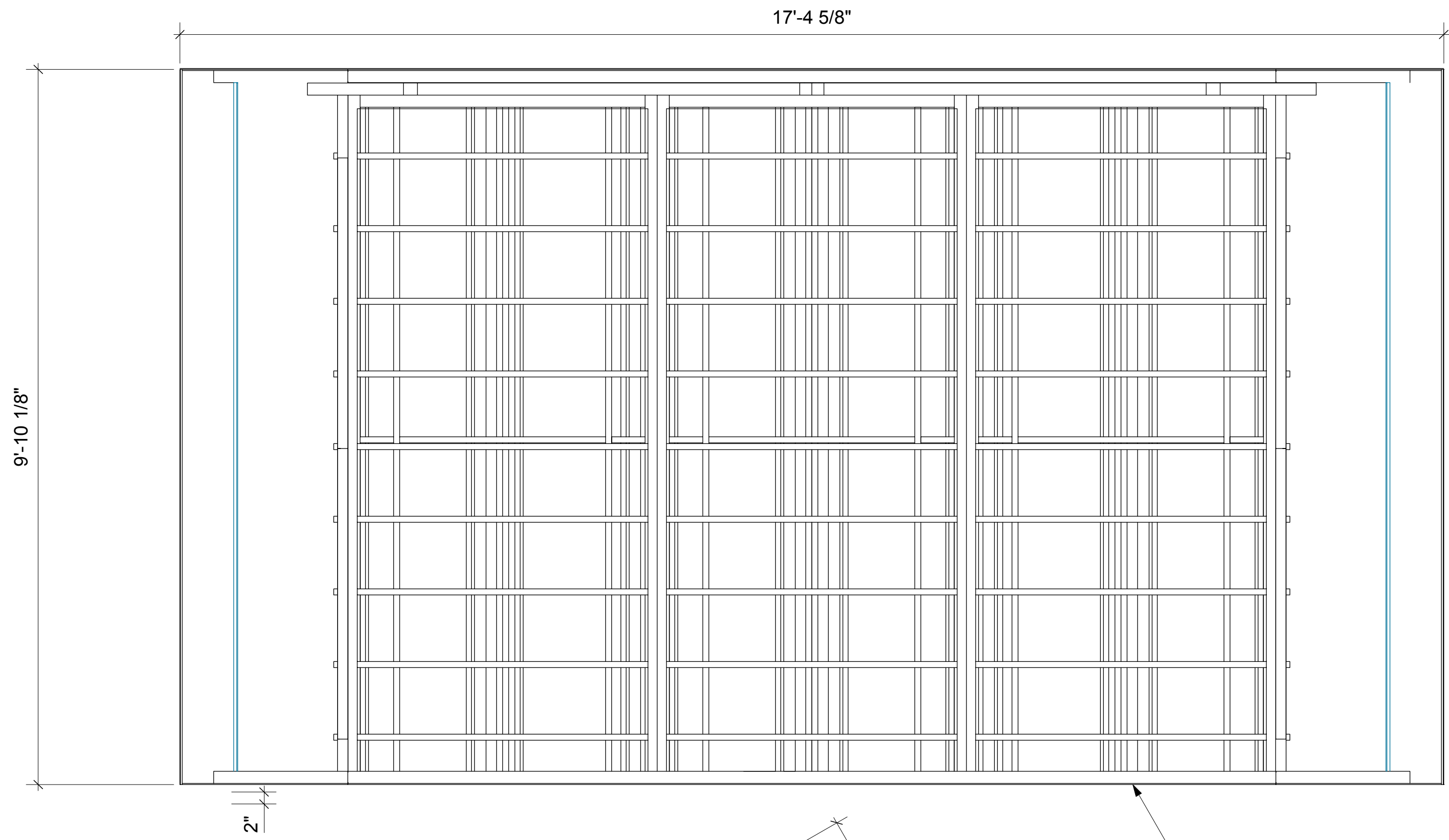

1 ELEVATION  
Scale: 3/4" = 1'-0"

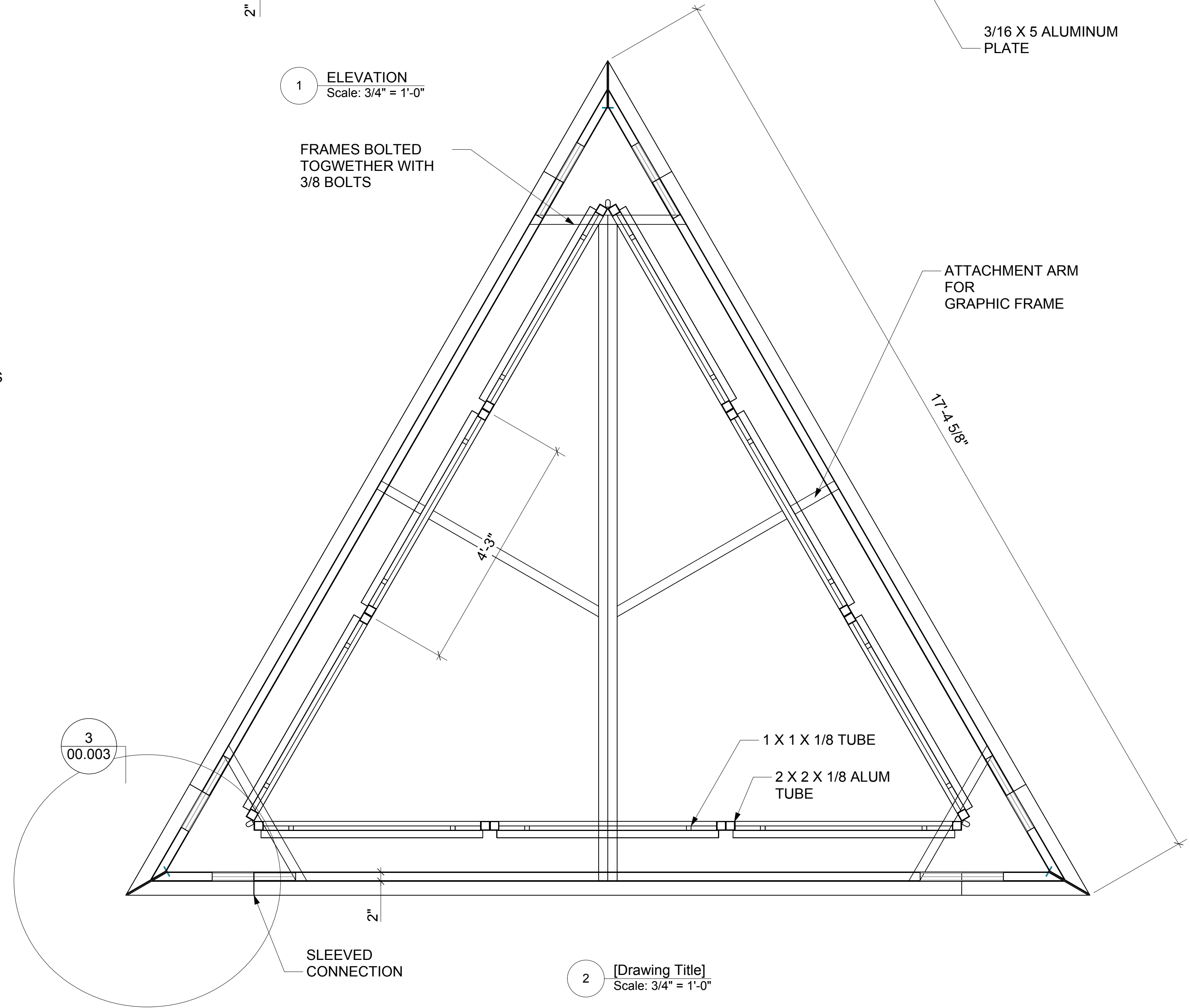

2 [Drawing Title]  
Scale: 3/4" = 1'-0"

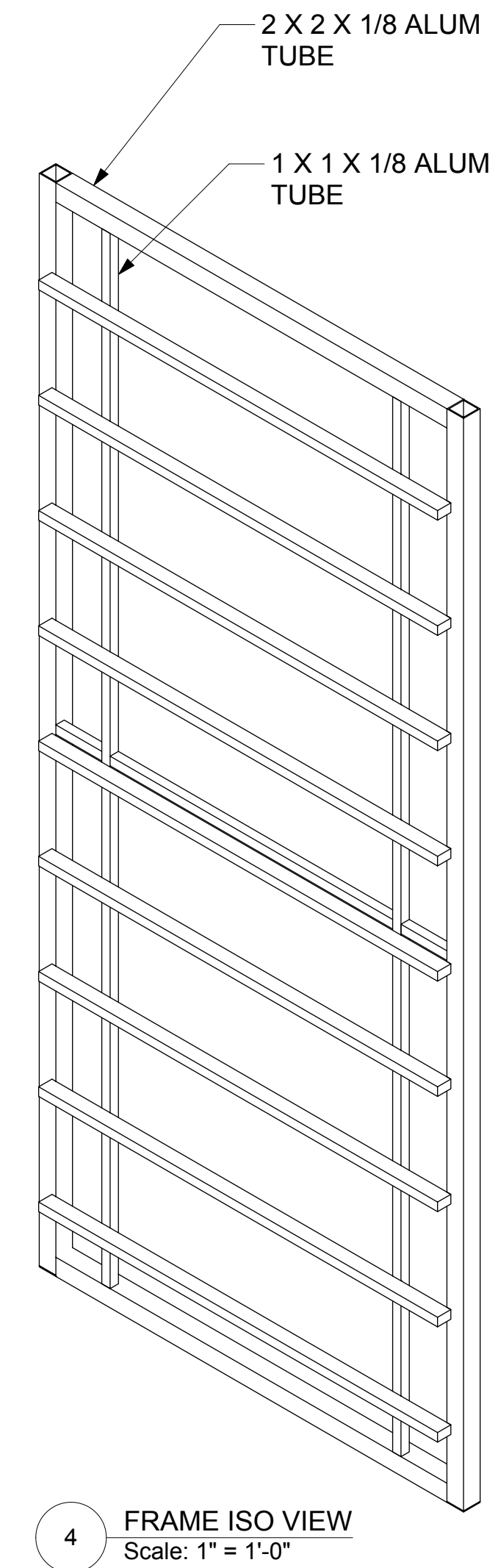
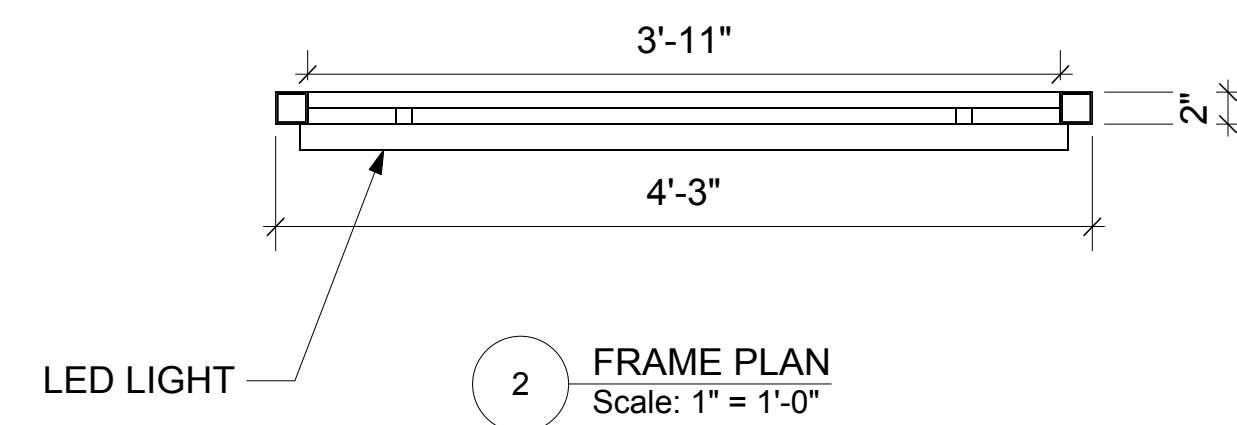
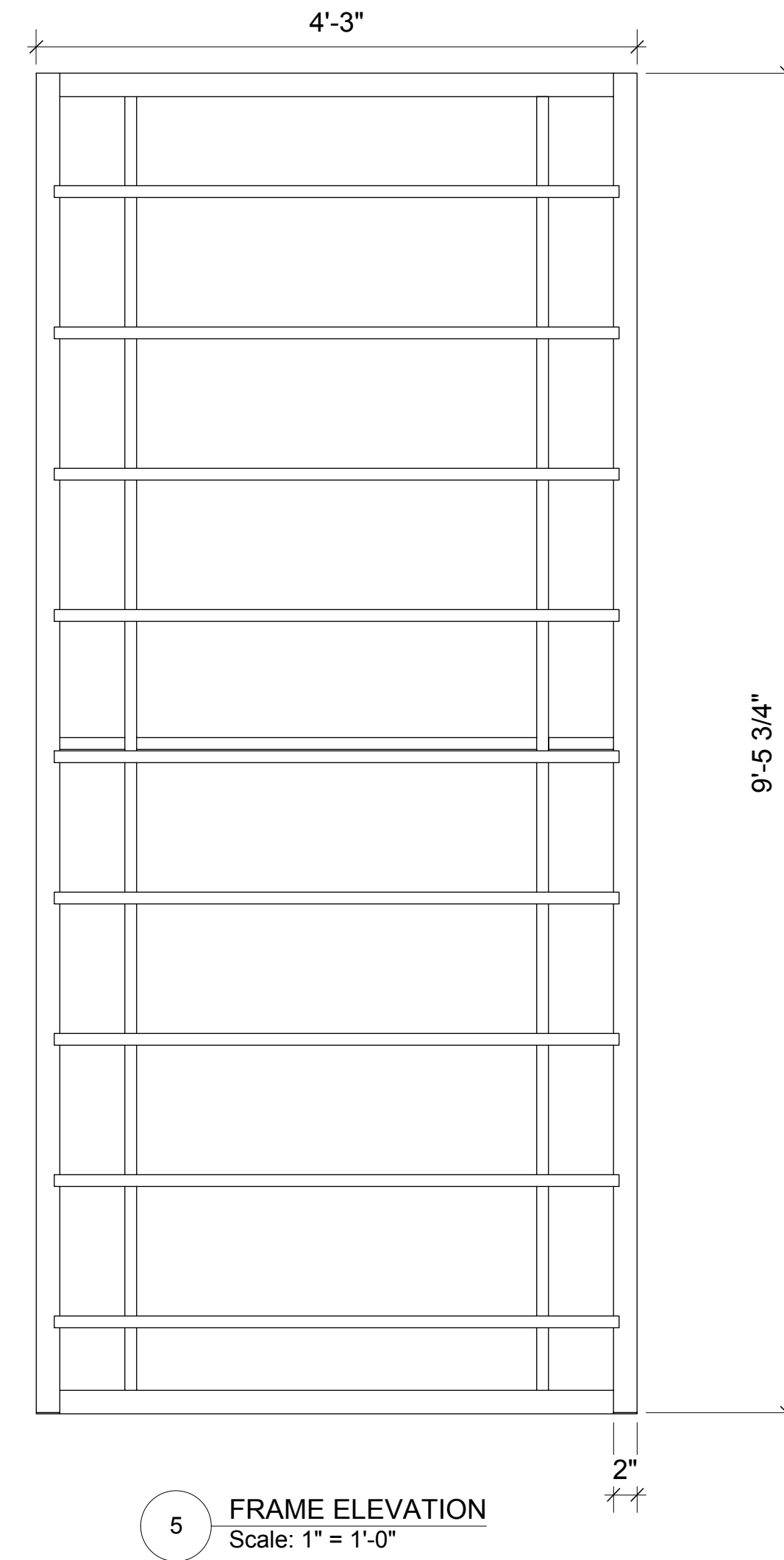
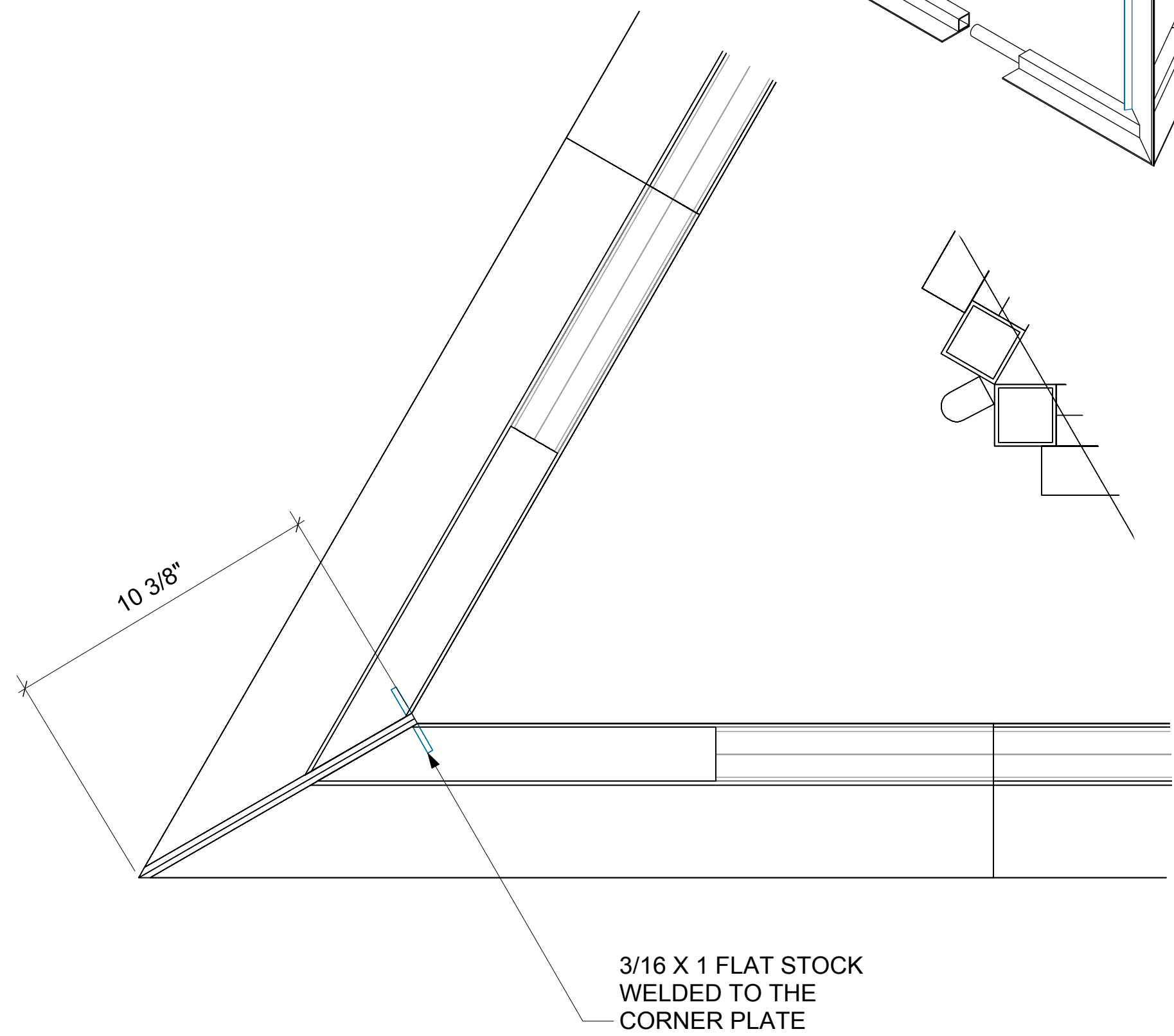
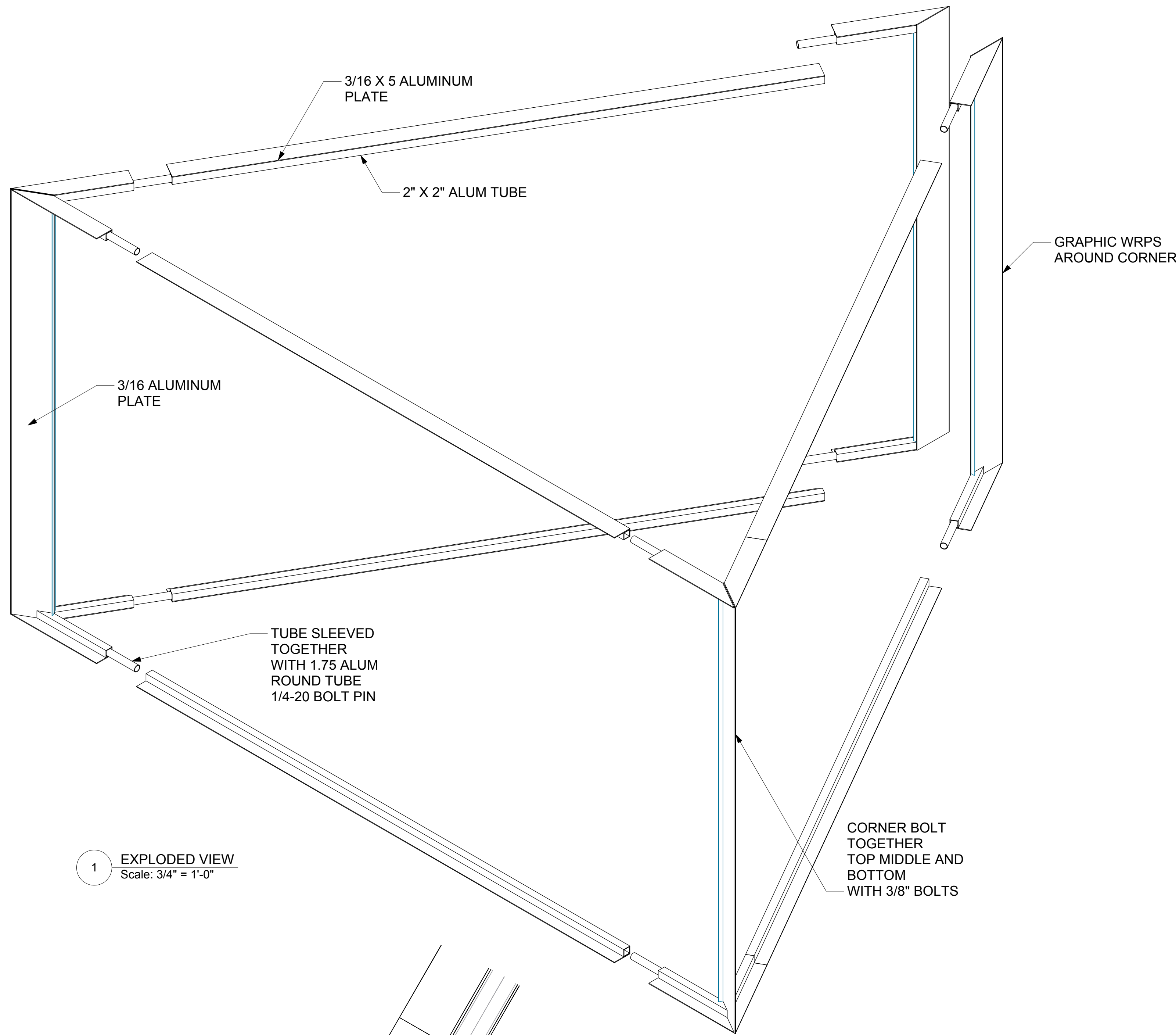

\*j 000(E 0) \* ~ ~ ~

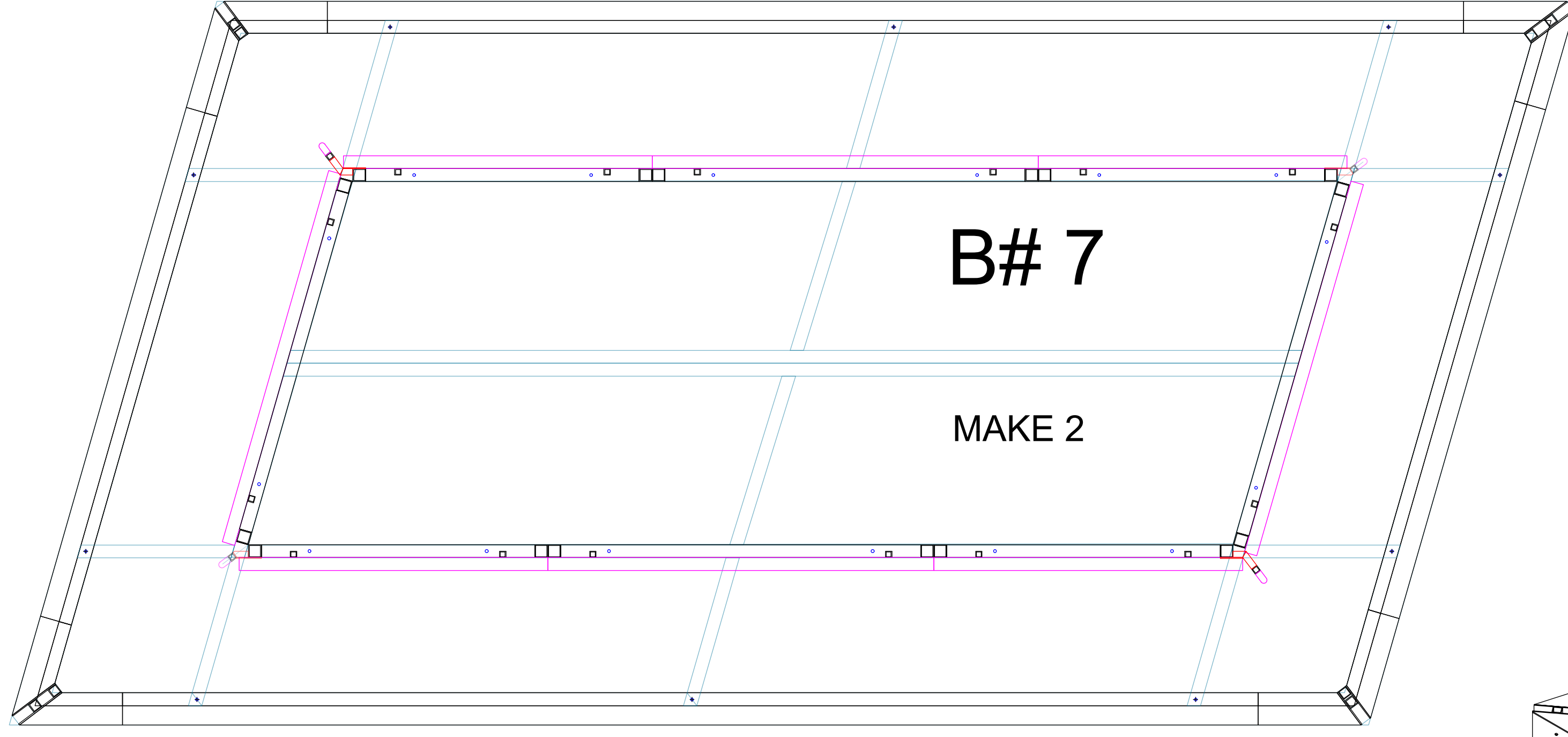

2 B7 PLAN VIEW  
Scale: 3/4" = 1'-0"

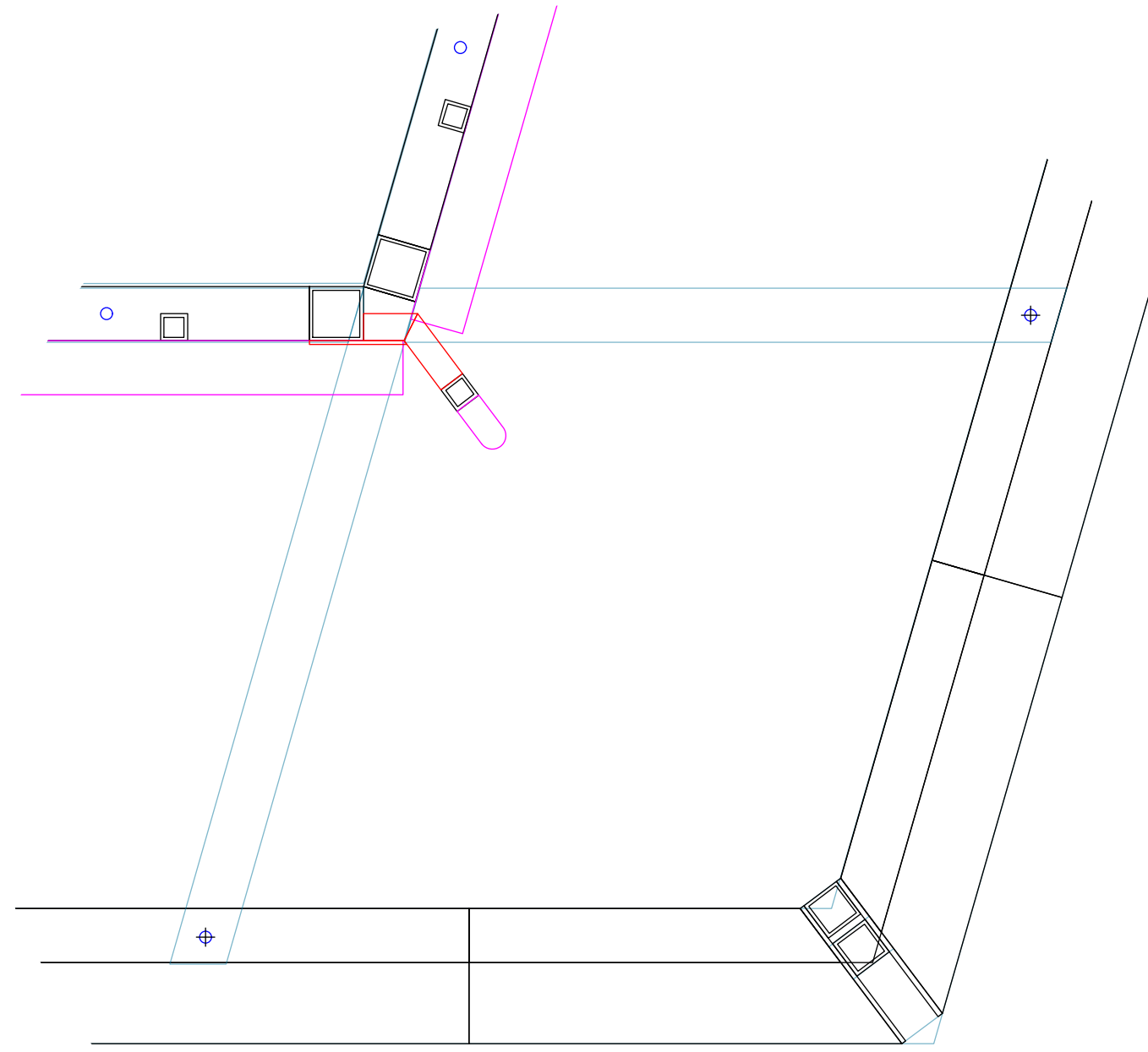

3 B7 CORNER DETAIL  
Scale: 2" = 1'-0"

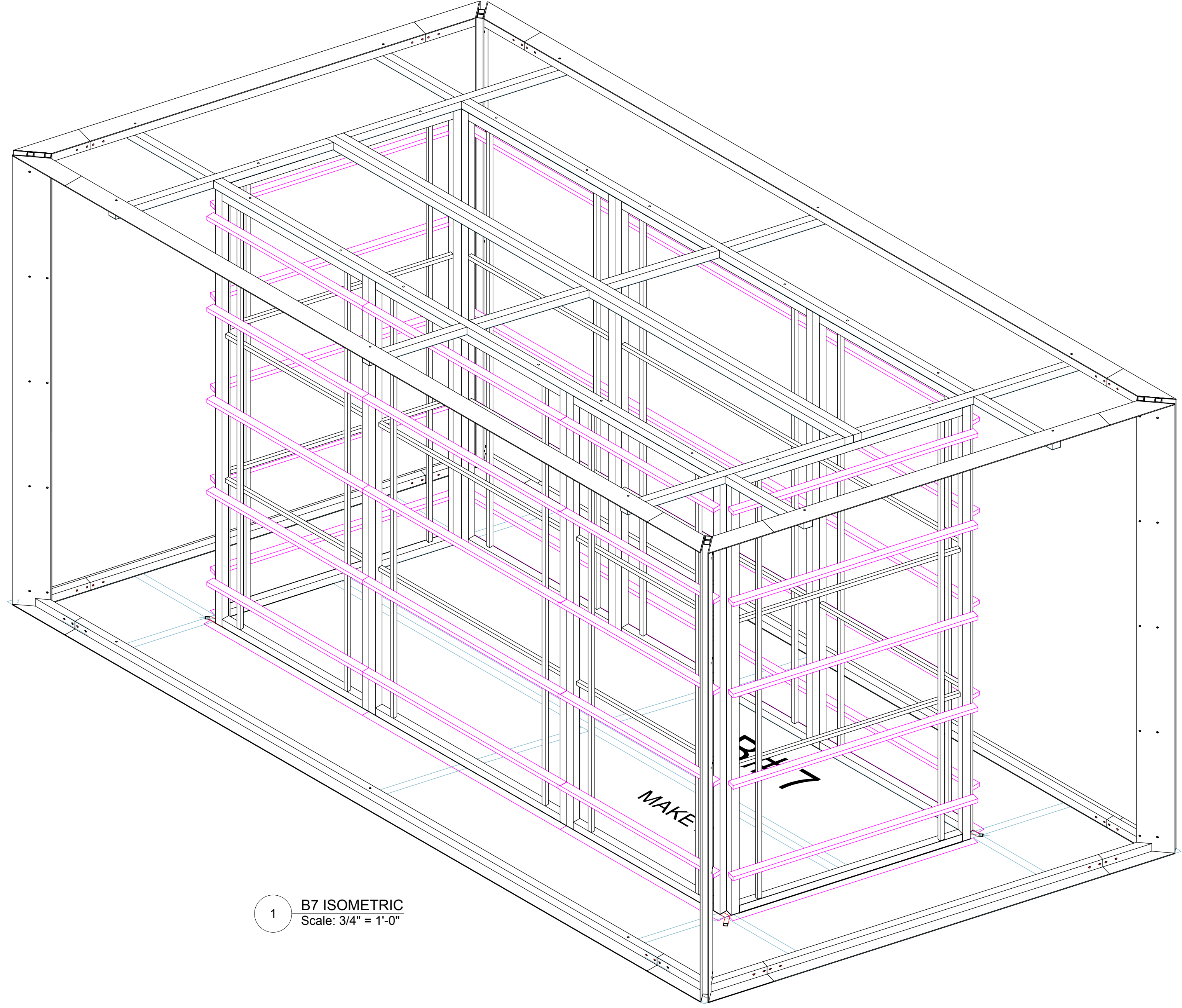

1 B7 ISOMETRIC  
Scale: 3/4" = 1'-0"

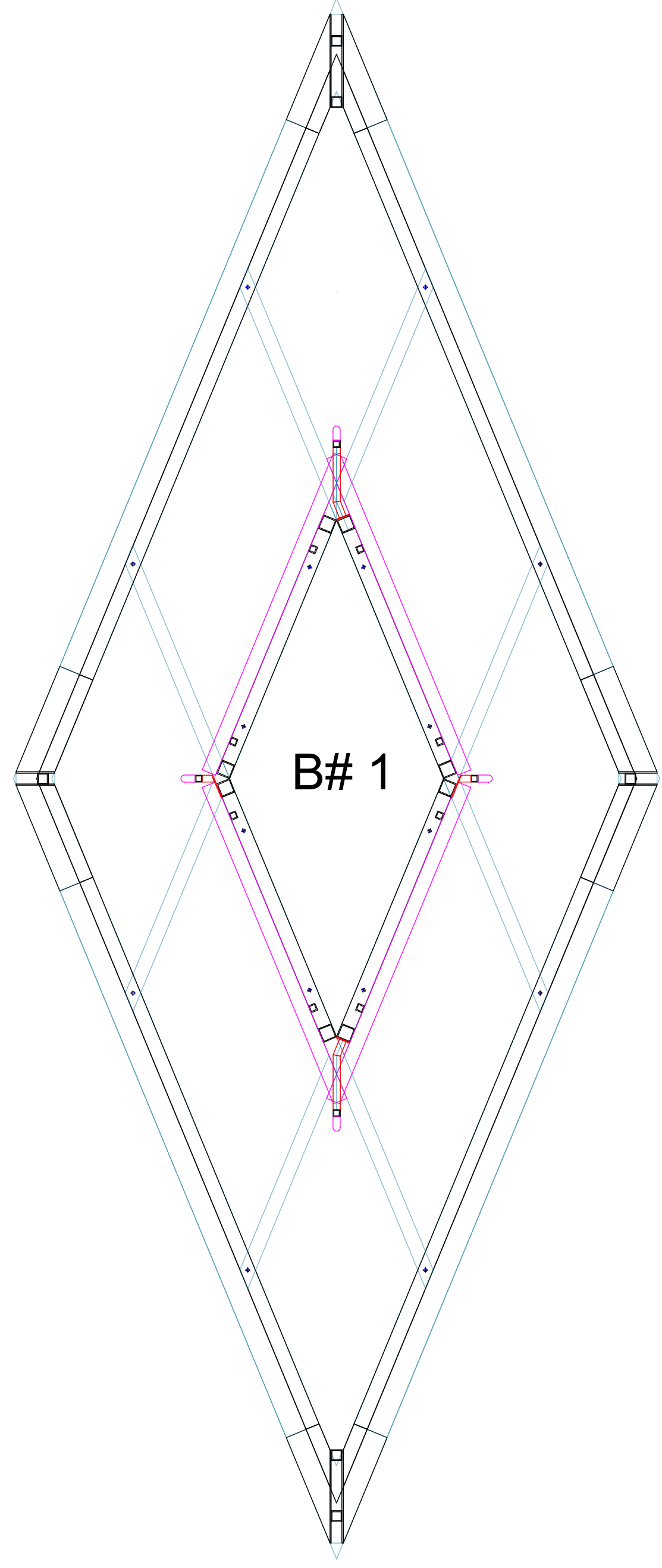

2 B1 PLAN VIEW  
Scale: 3/4" = 1'-0"

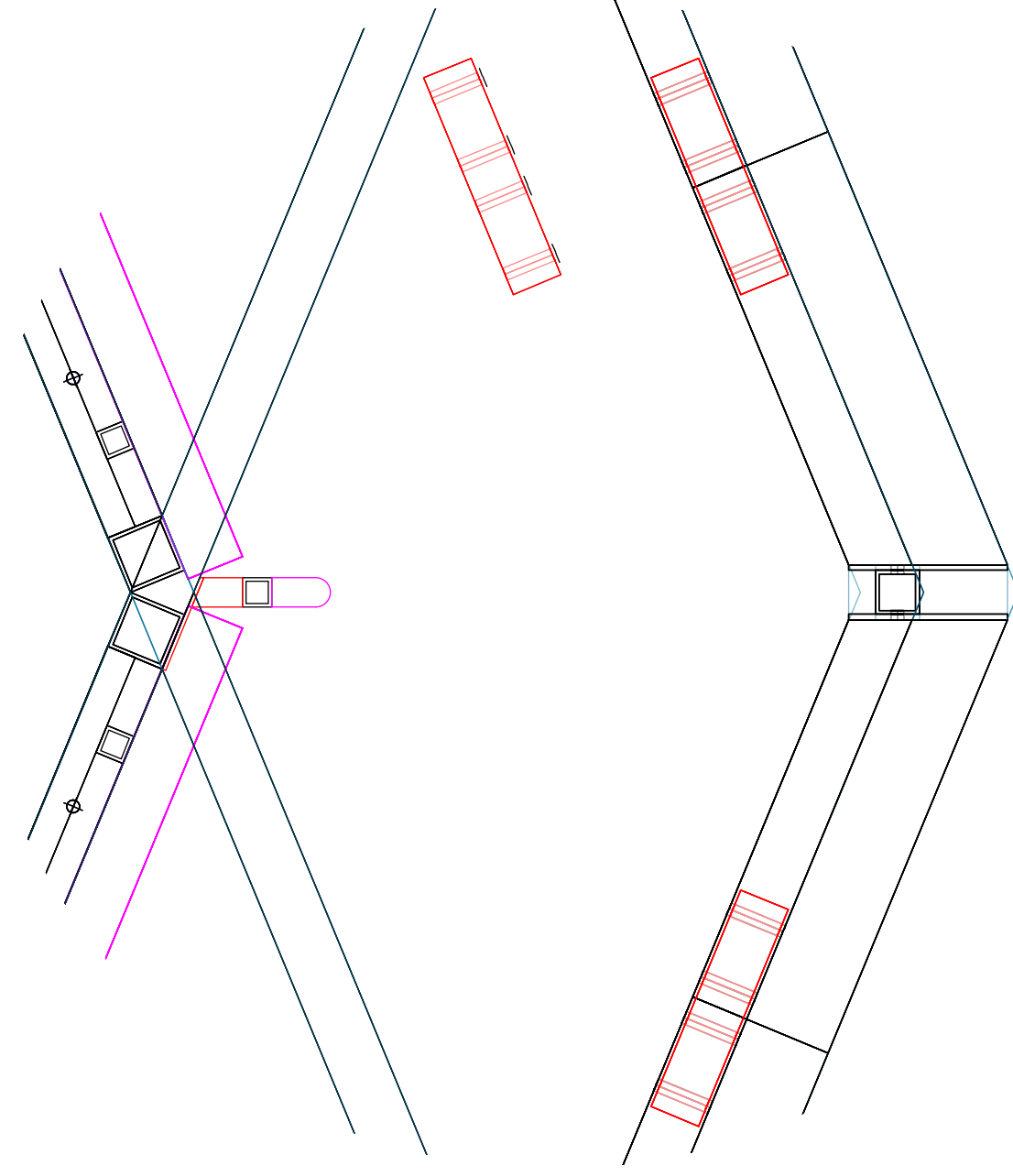

4 [Drawing Title]  
Scale: 2" = 1'-0"

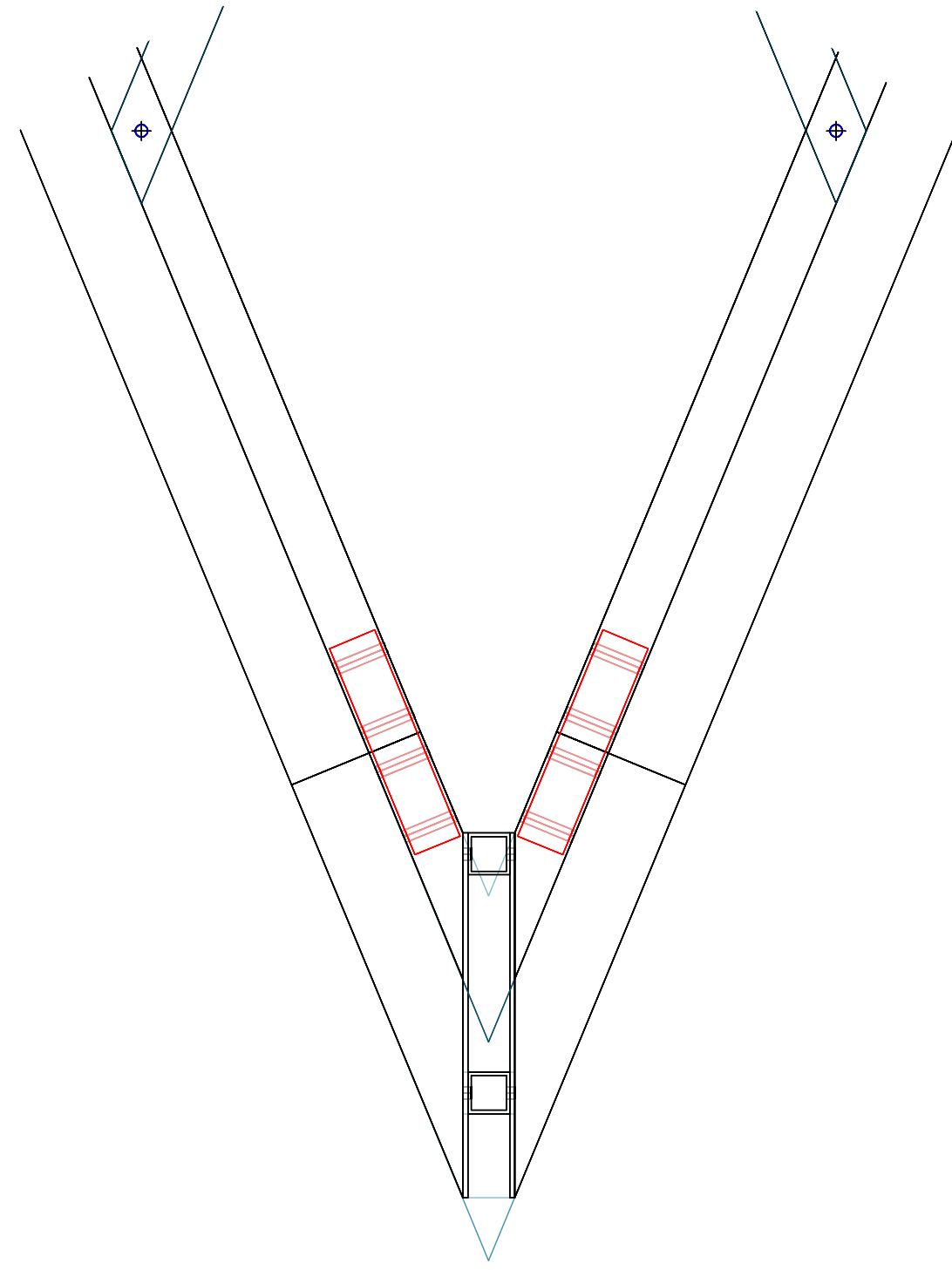

3 B1 CORNER DETAIL 1  
Scale: 2" = 1'-0"

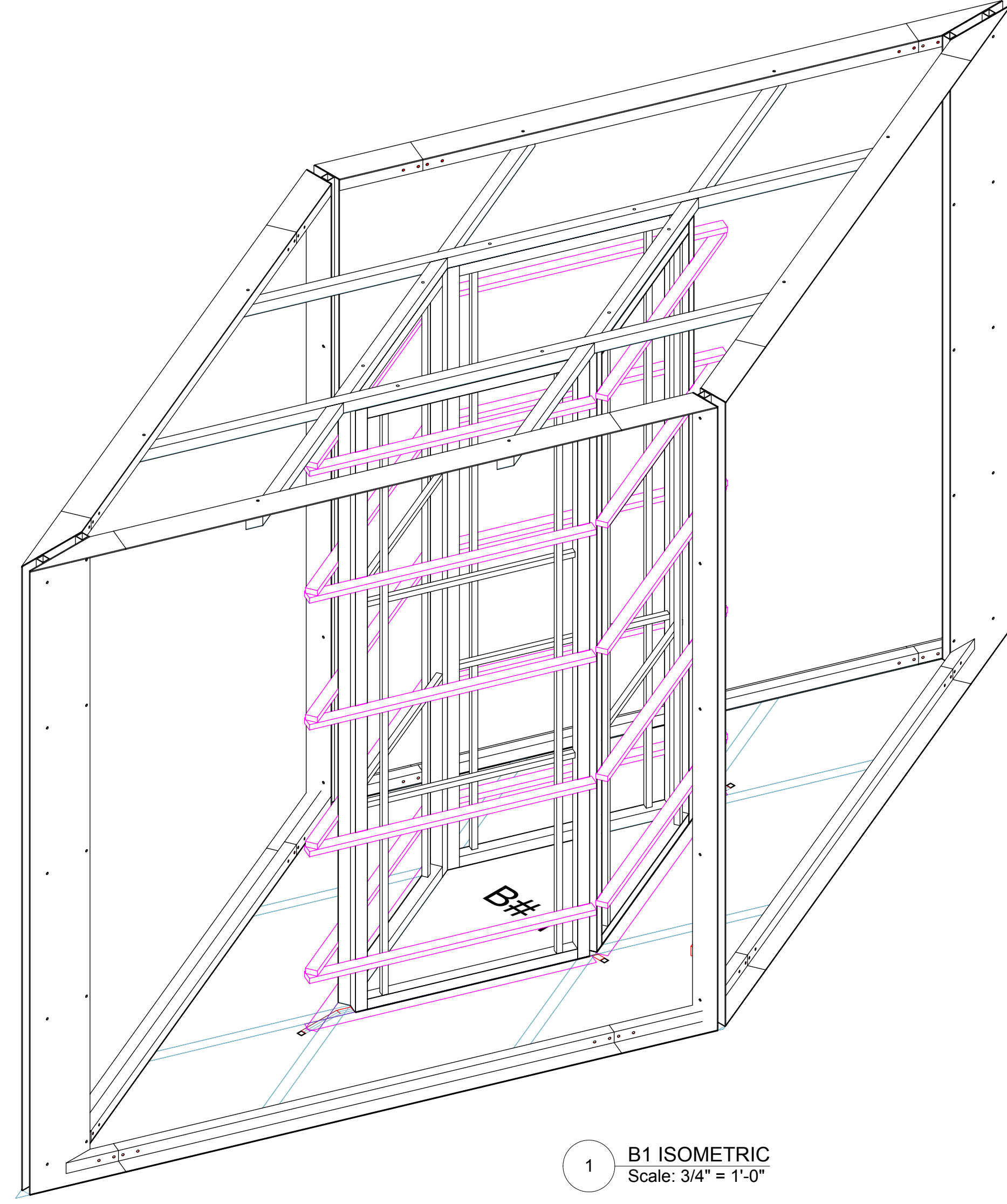

1 B1 ISOMETRIC  
Scale: 3/4" = 1'-0"

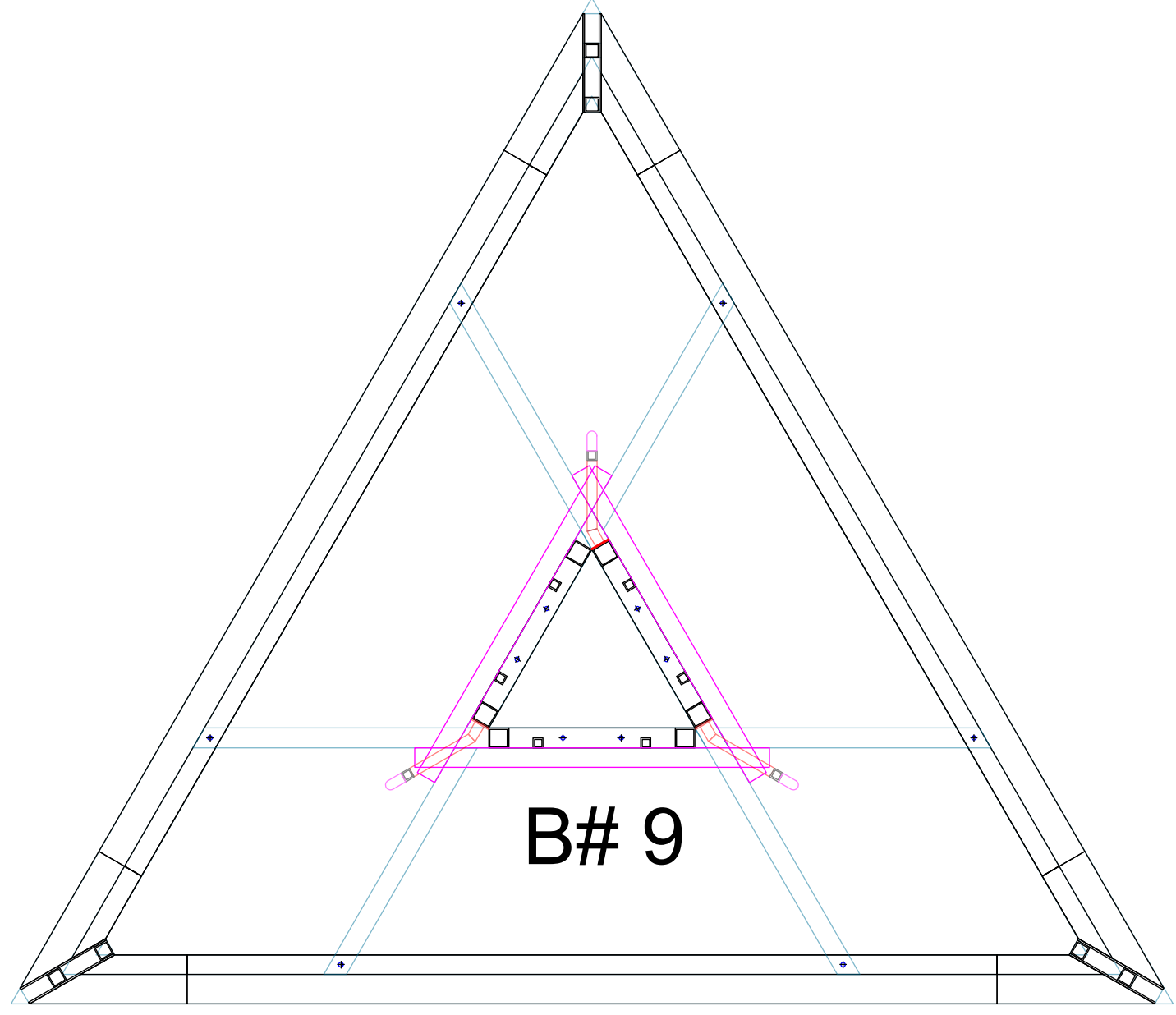

2 B9 PLAN VIEW  
Scale: 3/4" = 1'-0"

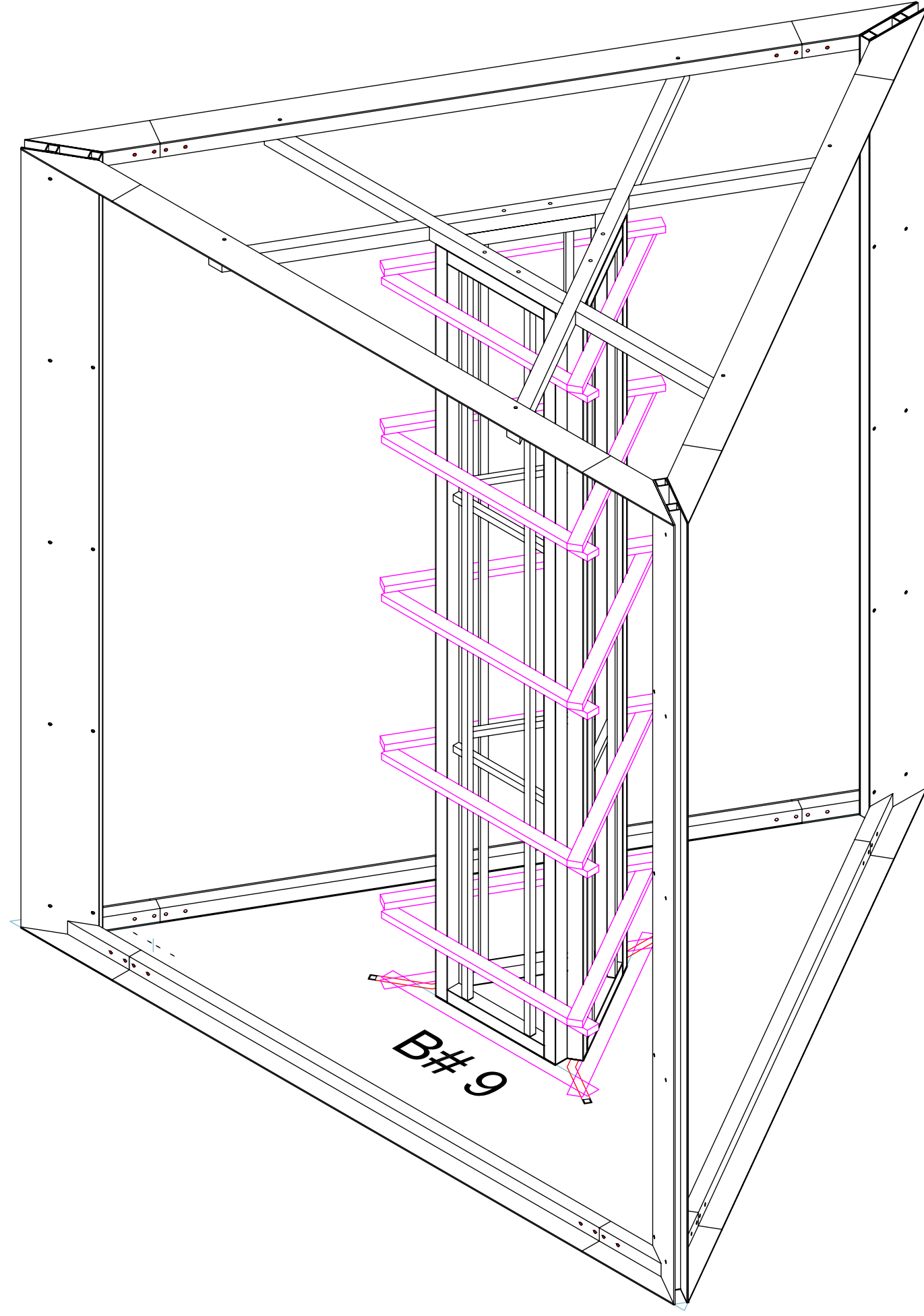

1 B9 ISOMETRIC  
Scale: 3/4" = 1'-0"

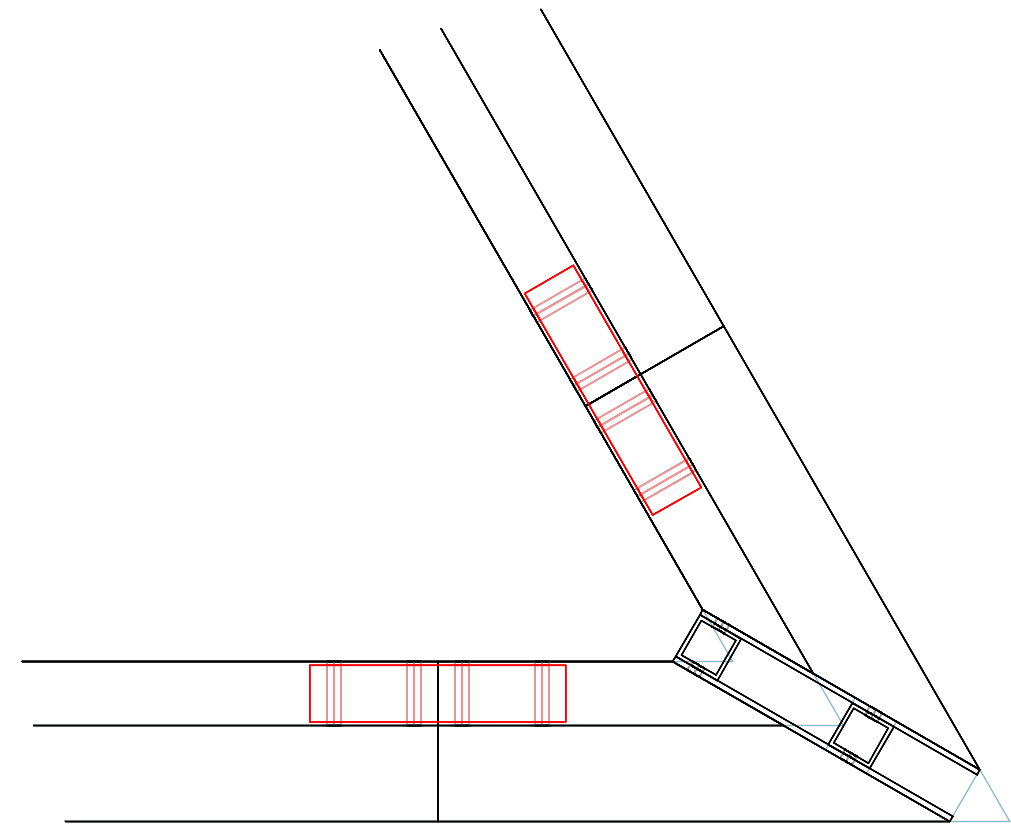

3 B9 CORNER DETAIL  
Scale: 2" = 1'-0"

\*j 000(E 0) \* ~ . . .

**JOB** SISTINE CHAPEL DISPLAY  
**DRAWING** B9 ISO & PLAN  
**ELEMENT** 02.012  
**DRAWING**

**NUMBER** 0000

**ATOMIC**  
ATOMIC DESIGN  
P: 717.626.8301  
F: 717.627.7736  
10 WYFIELD DRIVE  
LITITZ, PA 17543

**CONTACT**  
ACCOUNT MANAGER: Doug Frawley / Joe McMonagale  
PROJECT MANAGER: KEITH REILLY  
DRAWING BY: JR

**PRINT INFO**  
DATE: 3/8/18  
SCALE: As noted.  
PAPER: 24" x 36"

PLEASE NOTE: THESE DESIGNS AND/OR DRAWINGS ARE A REPRESENTATION ONLY. THE DESIGNER AND/OR CONTRACTOR IS NOT QUALIFIED TO DETERMINE WHETHER THE DRAWING AND/OR DESIGN MEETS STRUCTURAL SAFETY AND/OR BUILDING CODE REQUIREMENTS. ANY AND ALL ASPECTS OF THIS DRAWING ARE SUBJECT TO CHANGE. ALL DIMENSIONS SCALED OR LISTED ARE APPROXIMATE.

FILE NAME: grp2\_Sistine\_Graphics\_Frame\_06-06-17\_746\_PWL\_2018.rvt