

END VIEW TRACK #2

1	2	3	4	5	6	7	8	9	10	11	12	13	14	15	
TOLERANCES UNO		GENERAL NOTES UNO		PROJECTION		ID		DESCRIPTION		BOM		PART #		NOTE UNIT QUA T. QUA	
0.x	±0.015"	INTERPRET PER PRGNW CAD STAND.		PROJECTION											
0.xx	±0.010"	STEEL WELDS PER AWS D1.1		(US)											
0.xxx	±0.005"	BREAK SHARP EDGES TO R0.01"													
FRACTION	1/32"	MACHINE FINISHES 125 OR BETTER													
ANGLE	±0.5°														

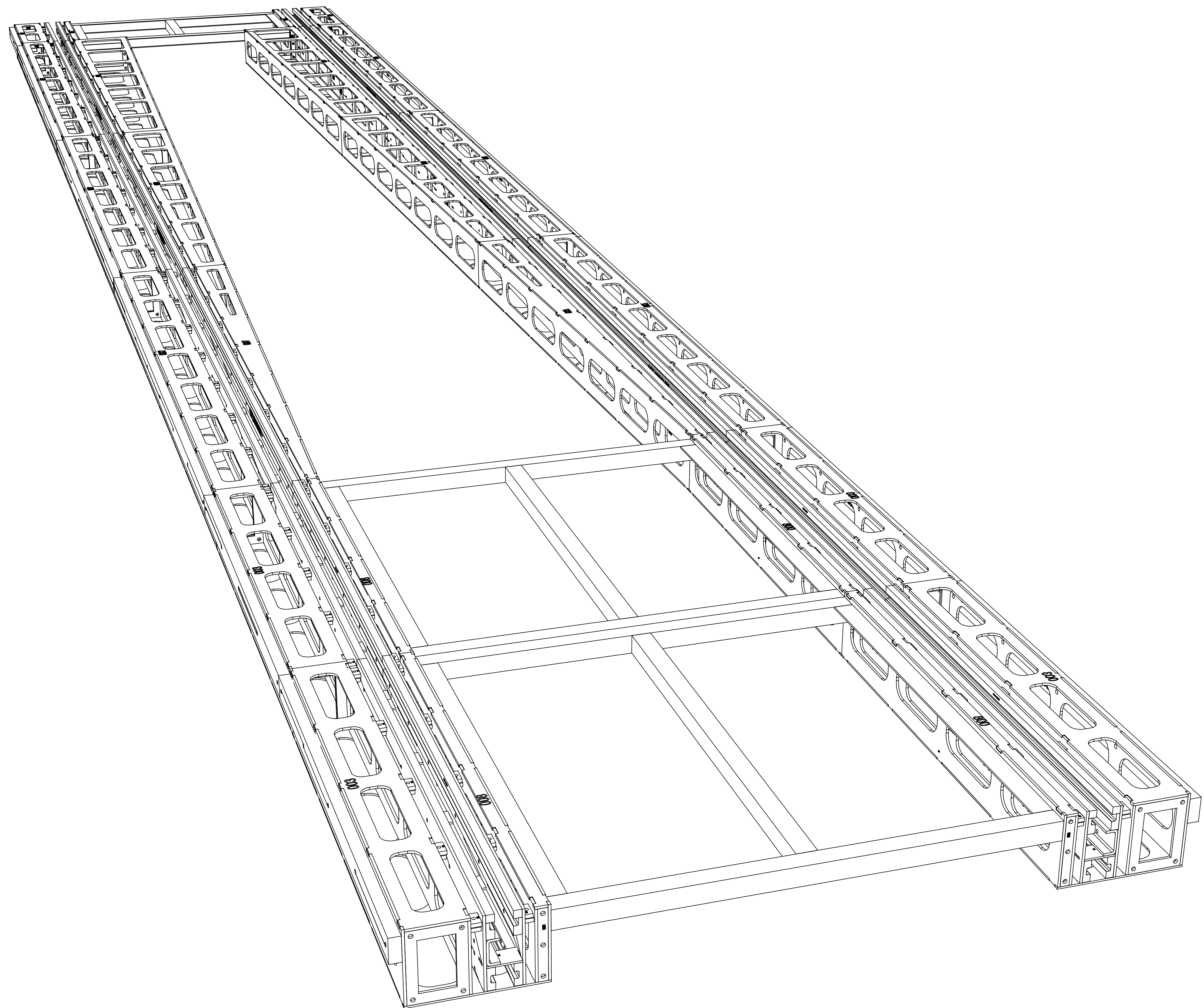

TOLERANCES UNO		GENERAL NOTES UNO		PROJECTION (US)
0.x	±0.015"	INTERPRET PER PRGNW CAD STAND.		
0.xx	±0.010"	STEEL WELDS PER AWS D1.1		
0.xxx	±0.005"	BREAK SHARP EDGES TO R0.01"		
FRACTION	1/32"	MACHINE FINISHES 125	OR BETTER	
ANGLE	±0.5°			

ID	DESCRIPTION	BOM	PART #	NOTE	UNIT	QUA	T. QUA
----	-------------	-----	--------	------	------	-----	--------

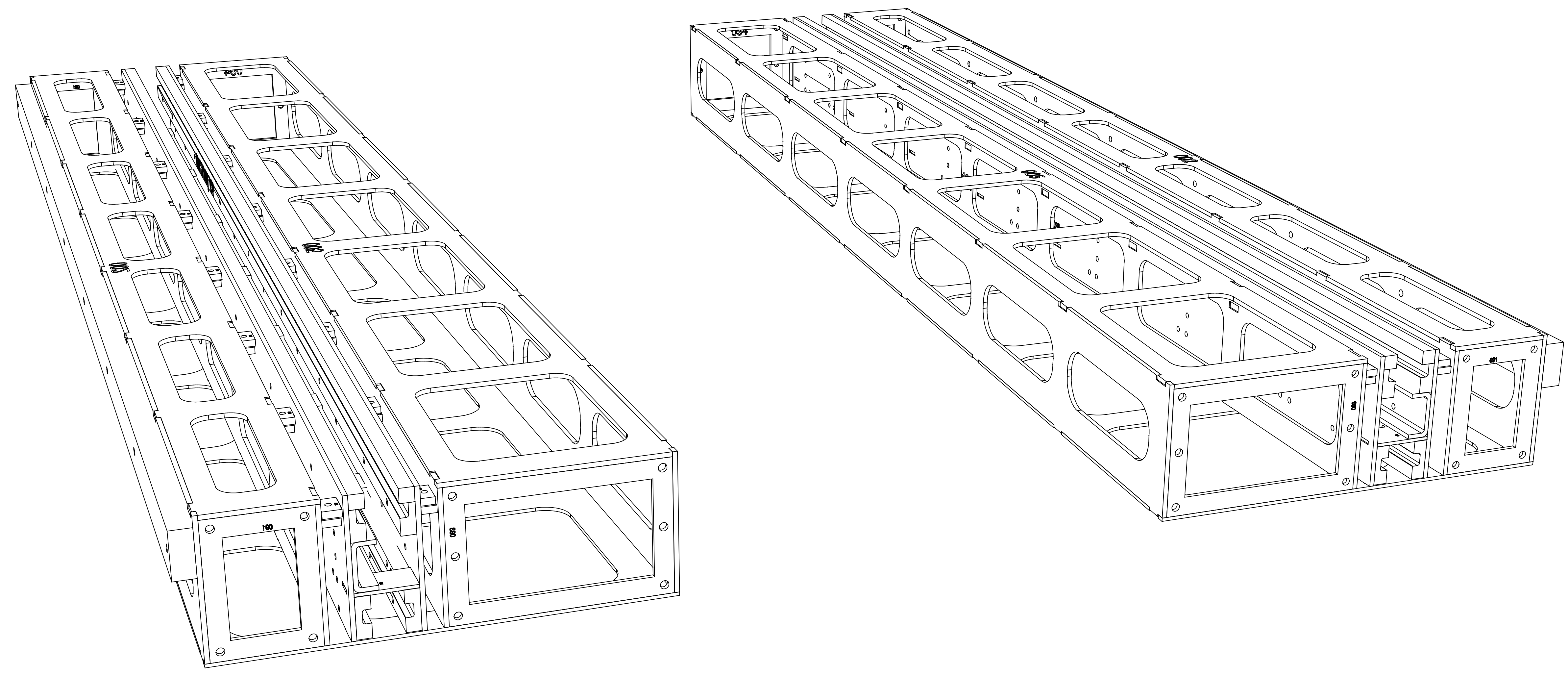

TT-05

TOLERANCES UNO	
0.x	±0.015"
0.xx	±0.010"
0.xxx	±0.005"
FRACTION	1/32"
ANGLE	±0.5°

GENERAL NOTES UNO  
 INTERPRET PER PRGNW CAD STAND.  
 STEEL WELDS PER AWS D1.1  
 BREAK SHARP EDGES TO R0.01"  
 MACHINE FINISHES 125 OR BETTER

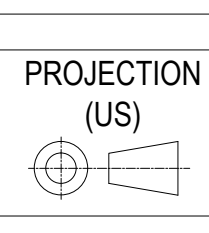

ID	DESCRIPTION	BOM	PART #	NOTE	UNIT	QUA	T. QUA
----	-------------	-----	--------	------	------	-----	--------

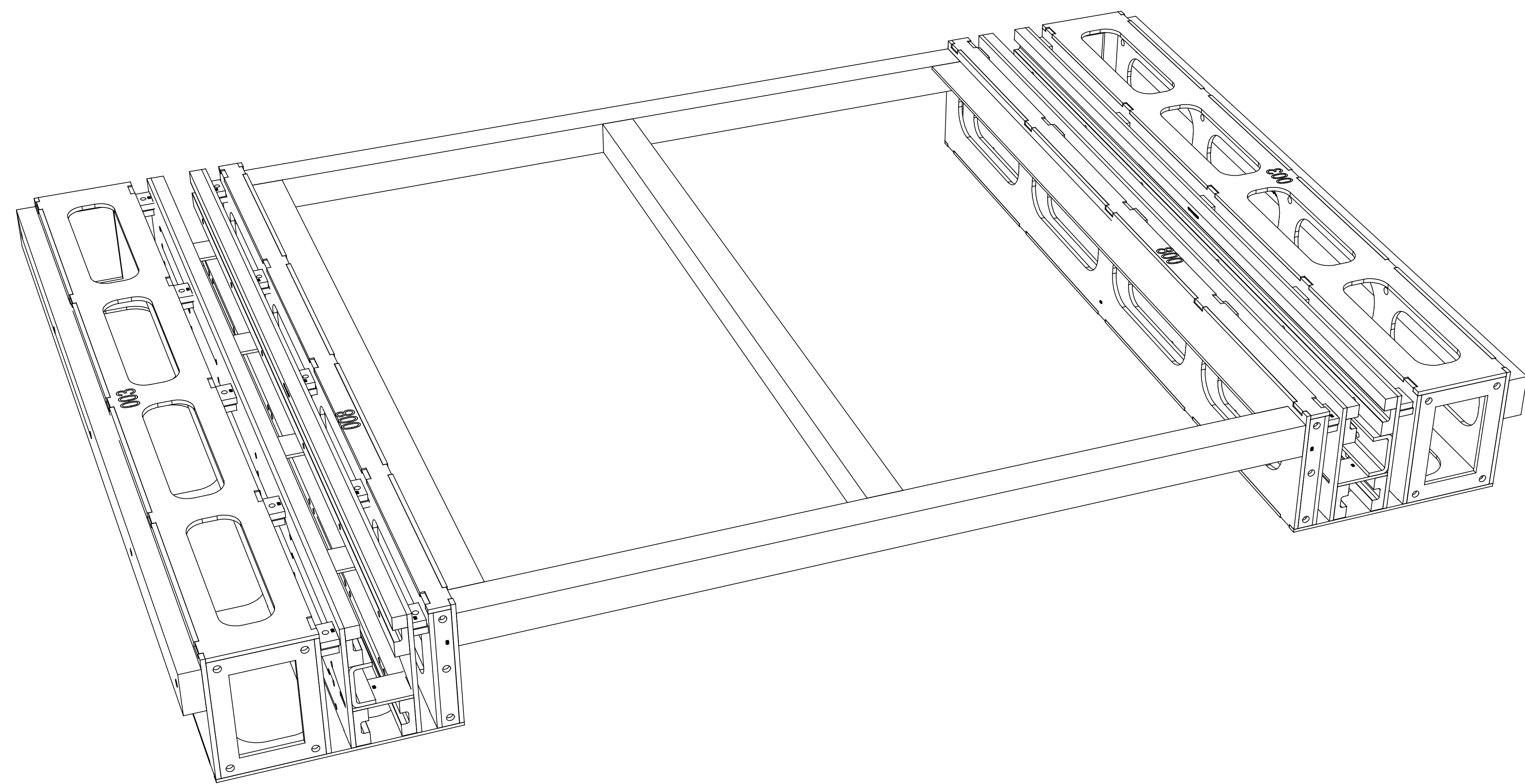

TRACK 2 AND 3

TT-06

TOLERANCES UNO		GENERAL NOTES UNO		PROJECTION (US)
0.x	±0.015"	INTERPRET PER PRGNW CAD STAND.		
0.xx	±0.010"	STEEL WELDS PER AWS D1.1		
0.xxx	±0.005"	BREAK SHARP EDGES TO R0.01"		
FRACTION	1/32"	MACHINE FINISHES 125	OR BETTER	
ANGLE	±0.5°			

ID	DESCRIPTION	BOM	PART #	NOTE	UNIT	QUA	T. QUA
----	-------------	-----	--------	------	------	-----	--------

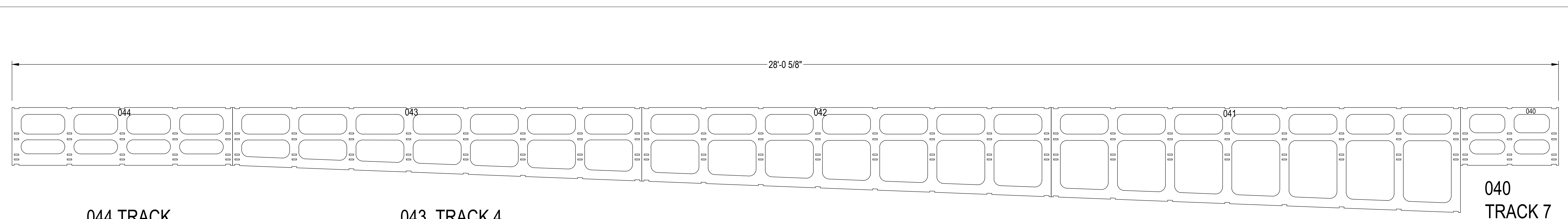

044 TRACK  
2 AND 3

043 TRACK 4

042 TRACK 5

041 TRACK 6

040  
TRACK 7

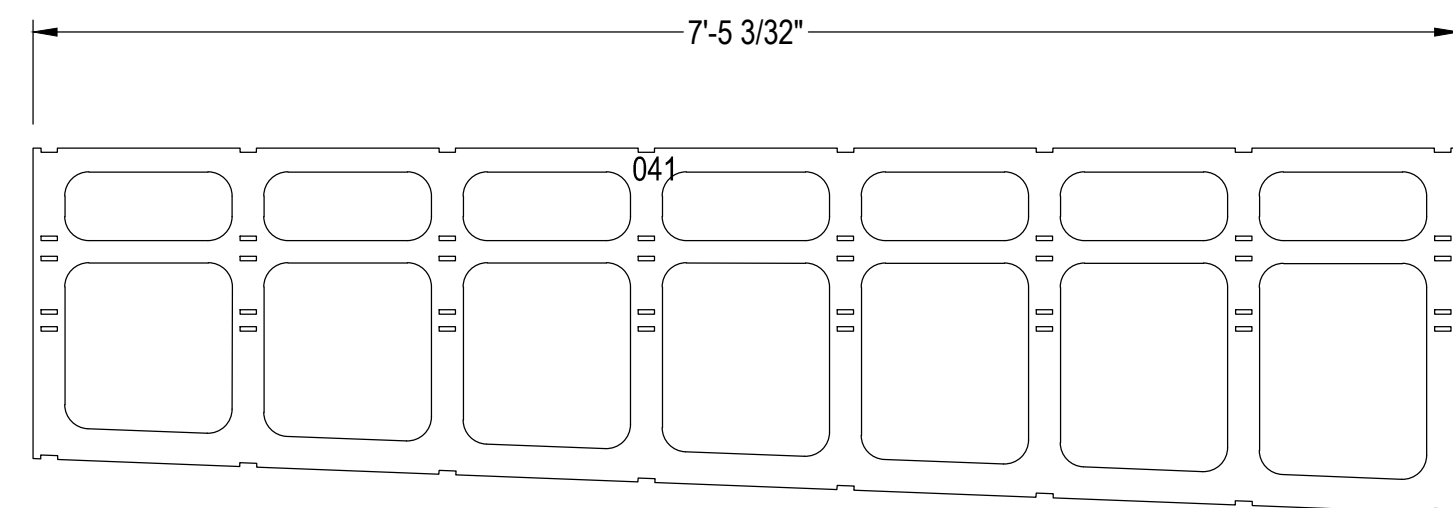

041 - 2 PIECES

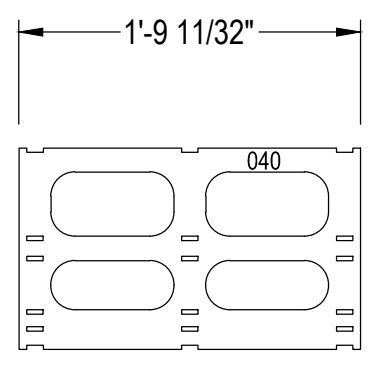

040 - 4 PIECES

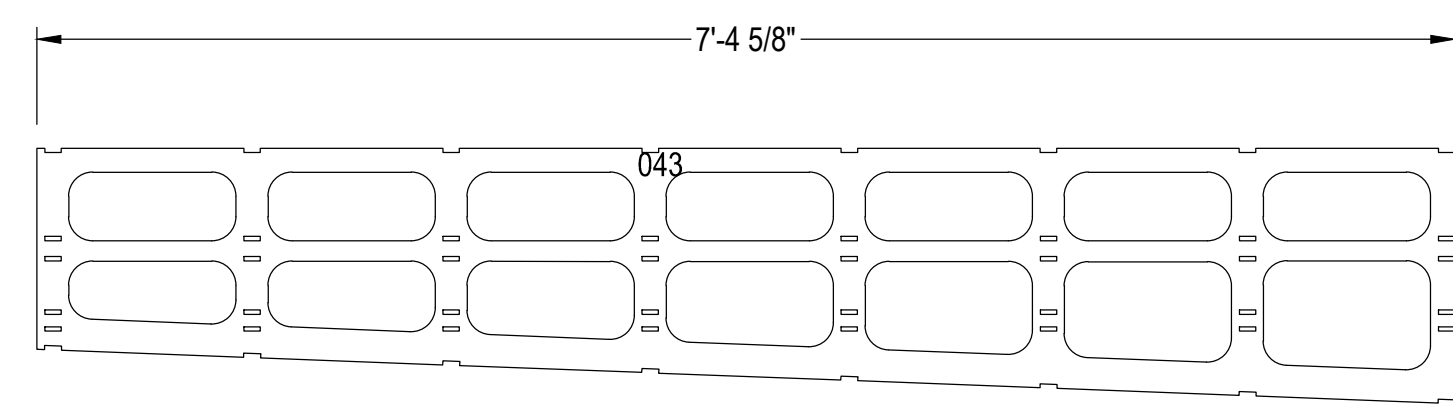

043 - 2 PIECE

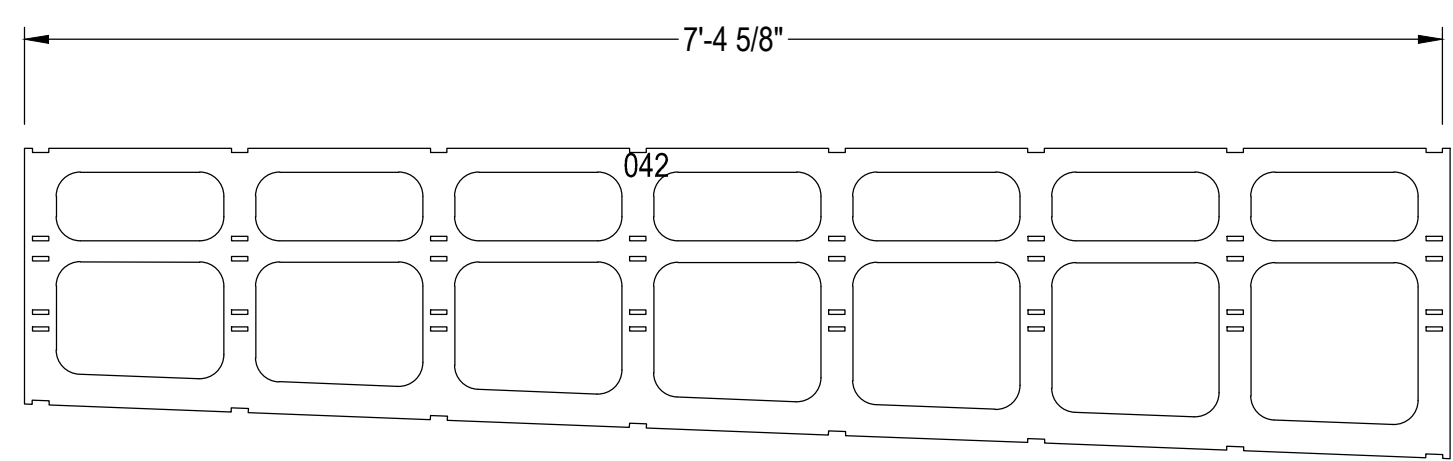

042 - 2 PIECES

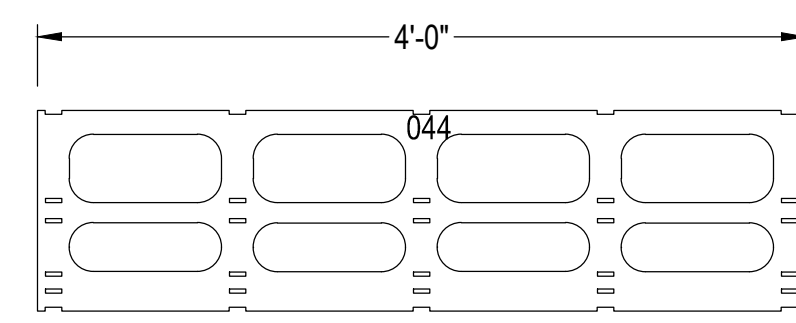

044 - 4 PIECES

BOTTOM PLATES  $\frac{3}{16}$  PLATE  
STAGE LEFT SHOWN  
REVERSE FOR STAGE RIGHT

TOLERANCES UNO		GENERAL NOTES UNO		PROJECTION (US)
0.x	±0.015"	INTERPRET PER PRGNW CAD STAND.		
0.xx	±0.010"	STEEL WELDS PER AWS D1.1		
0.xxx	±0.005"	BREAK SHARP EDGES TO R0.01"		
FRACTION	1/32"	MACHINE FINISHES 125	OR BETTER	
ANGLE	±0.5°			

ID	DESCRIPTION	BOM	PART #	NOTE	UNIT	QUA	T. QUA
----	-------------	-----	--------	------	------	-----	--------

# HEAVY RAIL

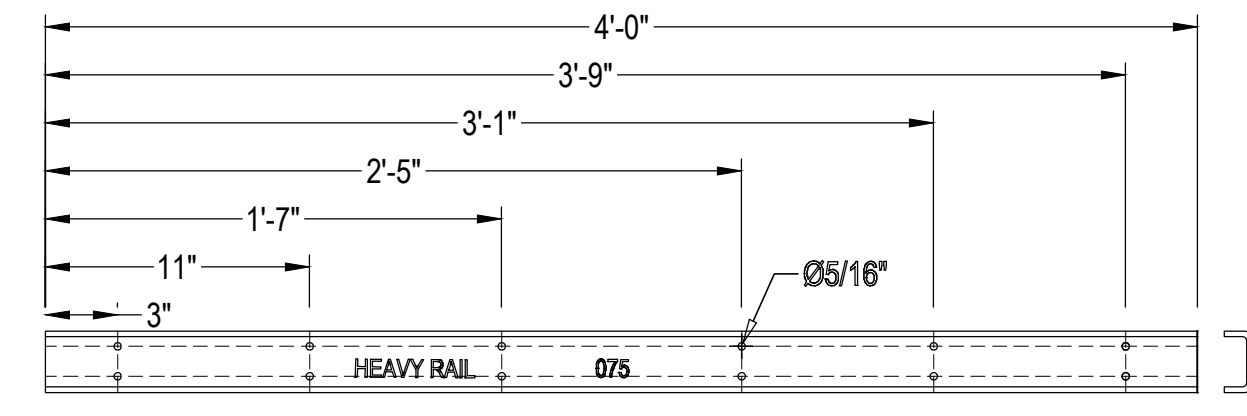

075 quan 4 pc

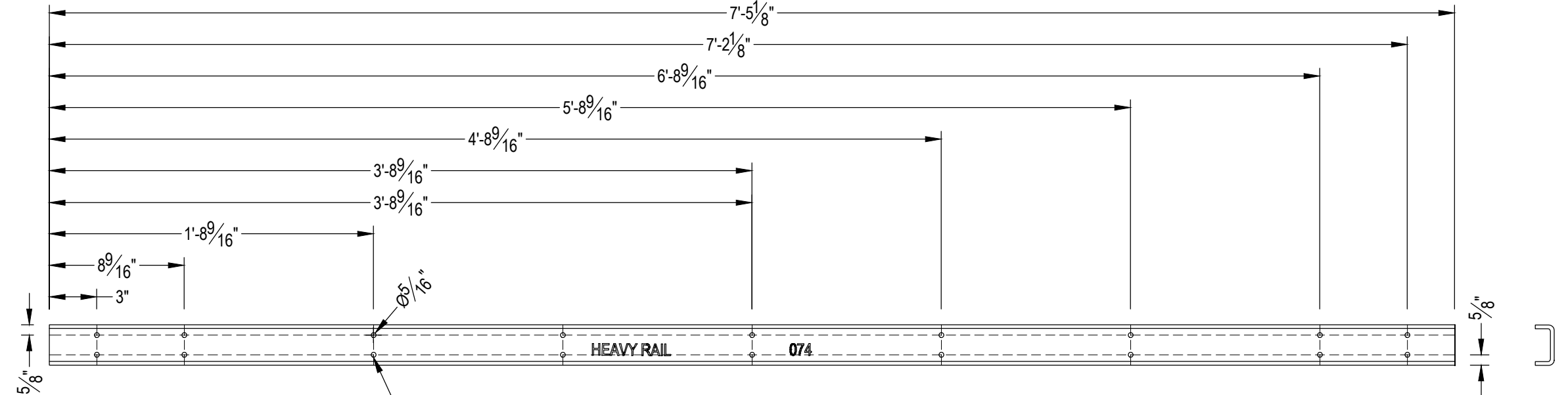

074 quan 6 pc

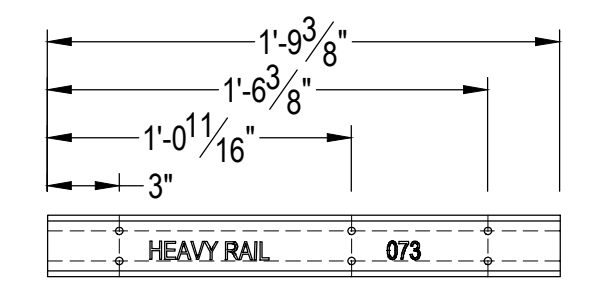

073 quan 2 pc

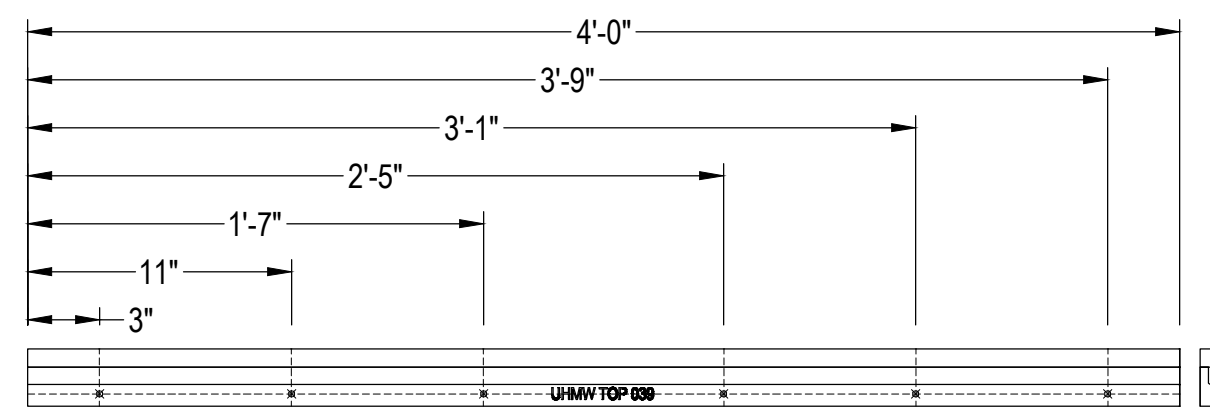

UHMW TOP 039 quan 8 pc

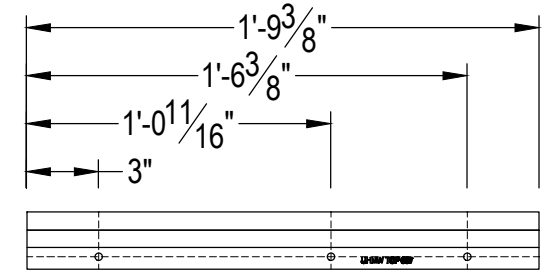

UHMW TOP 037 quan 4 pc

# UHMW

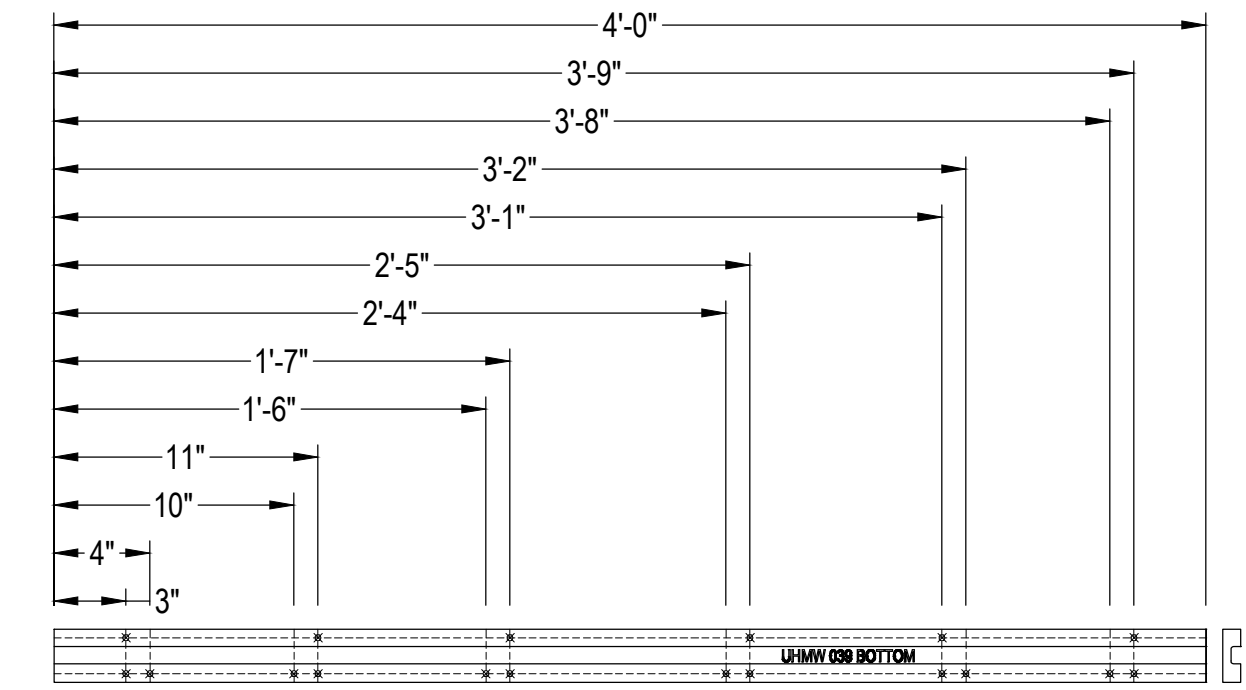

UHMW BOTTOM 039 quan 8 pc

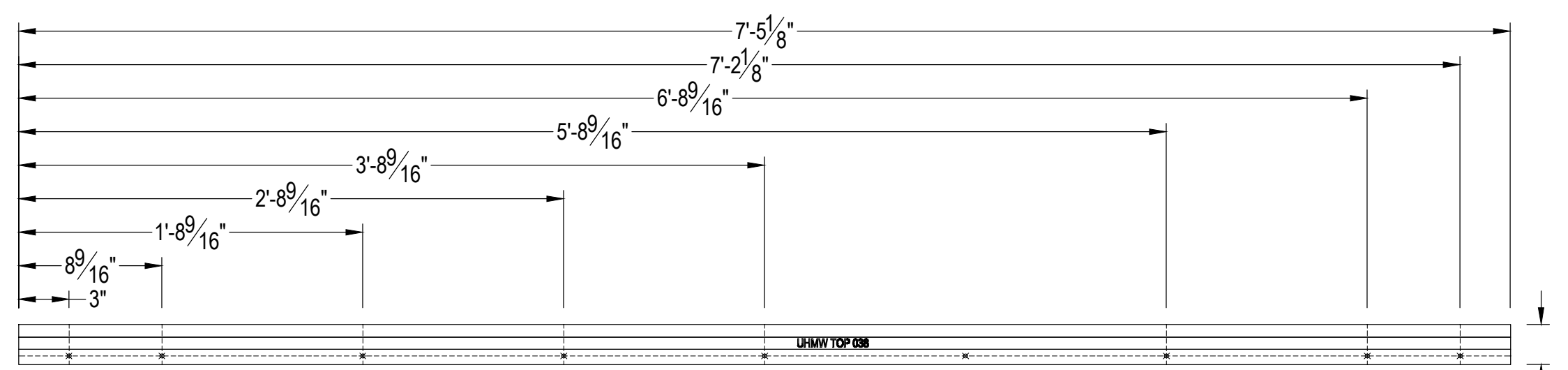

UHMW TOP 038 quan 12 pc

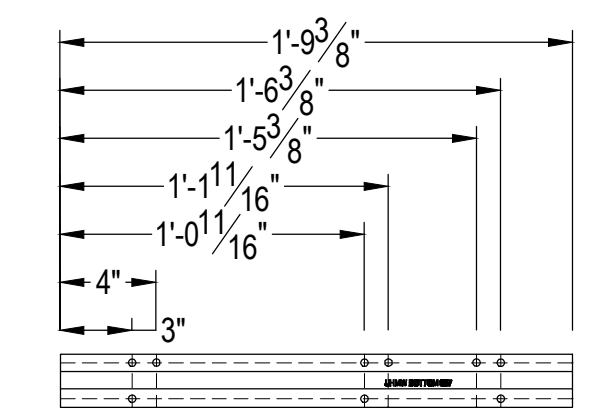

UHMW BOTTOM 037 quan 4 pc

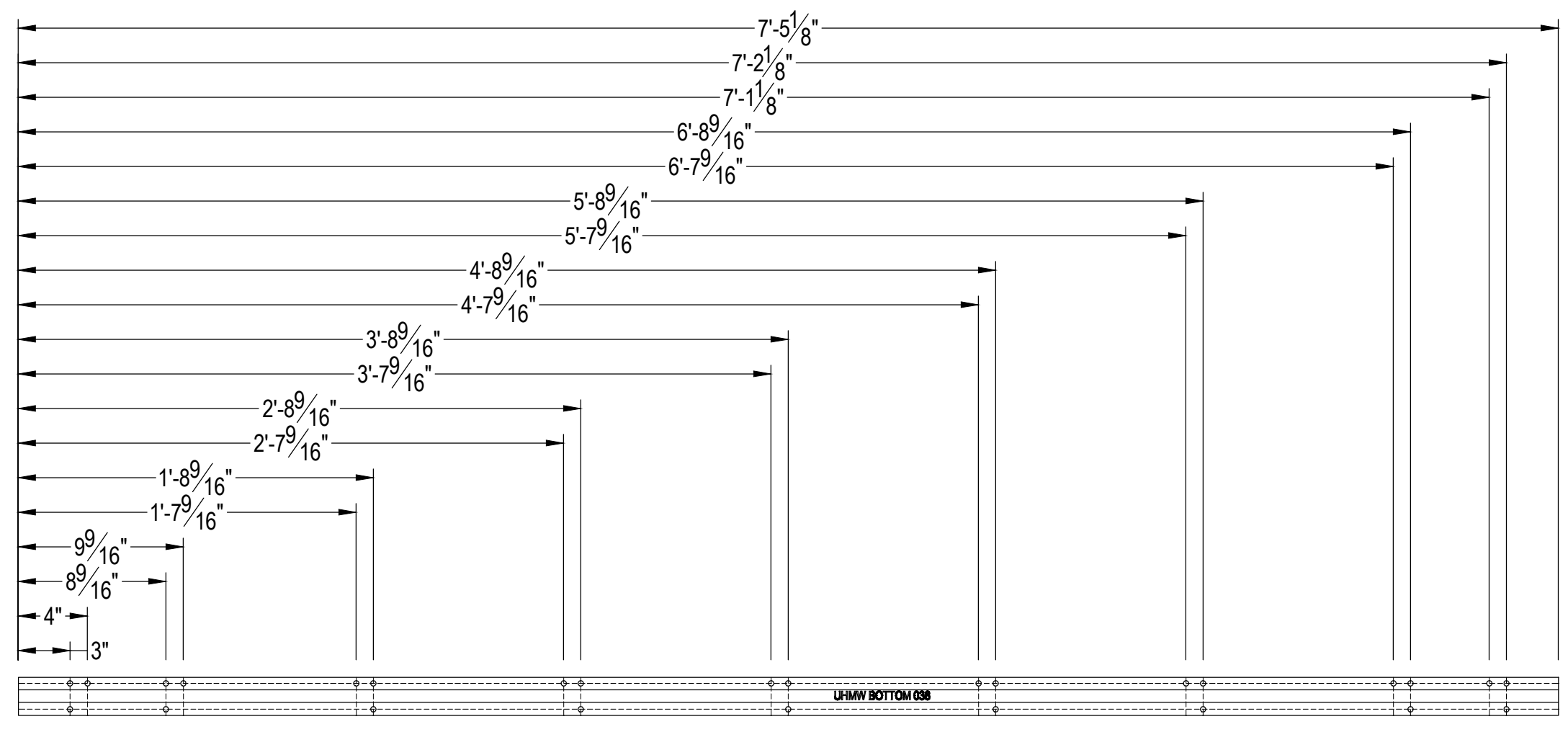

UHMW BOTTOM 038 quan 12 pc

TOLERANCES UNO		GENERAL NOTES UNO		PROJECTION (US)
0.x	±0.015"	INTERPRET PER PRGNW CAD STAND.		
0.xx	±0.010"	STEEL WELDS PER AWS D1.1		
0.xxx	±0.005"	BREAK SHARP EDGES TO R0.01"		
FRACTION	1/32"	MACHINE FINISHES 125	OR BETTER	
ANGLE	±0.5°			

ID	DESCRIPTION	BOM	PART #	NOTE	UNIT	QUA	T. QUA
----	-------------	-----	--------	------	------	-----	--------

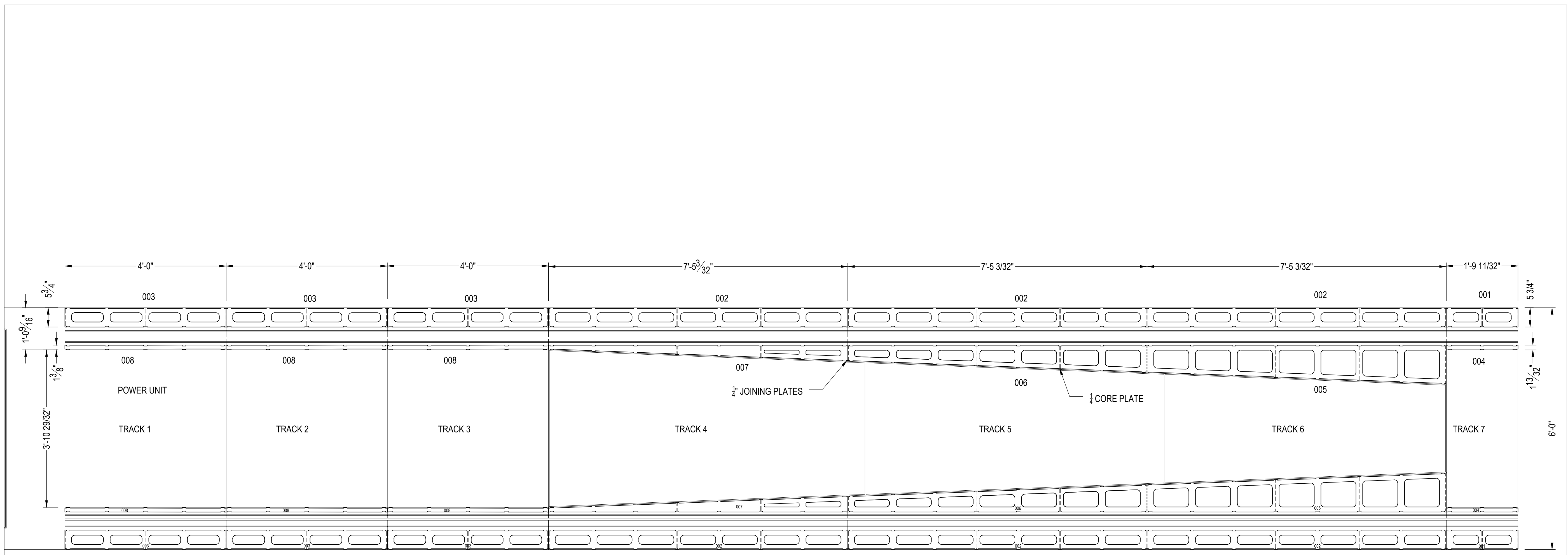

TOP VIEW SHOWING 1/4" TOP PLATES

TT-09

1 2 3 4 5 6 7 8 9 10 11 12 13 14 15 16 17 18 19 20 21 22 23 24 25 26 27 28 29 30 31

U  
T  
S  
R  
Q  
P  
O  
N  
M  
L  
K  
J  
I  
H  
G  
F  
E  
D  
C  
B  
A

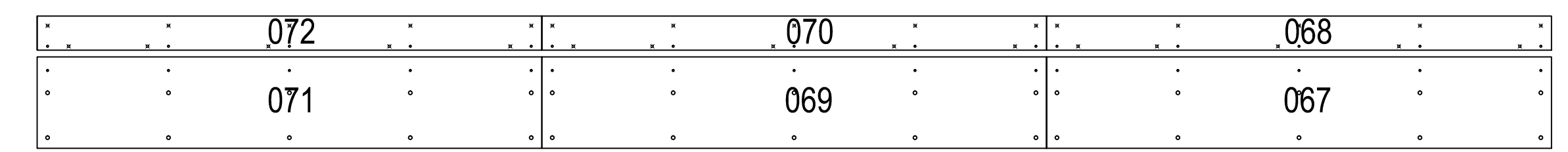
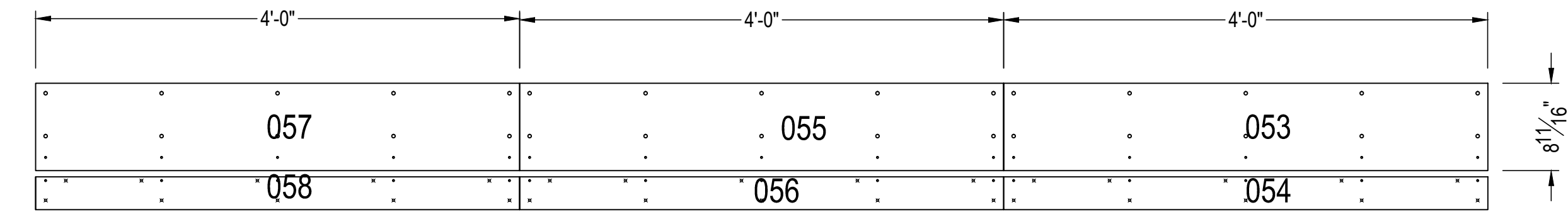
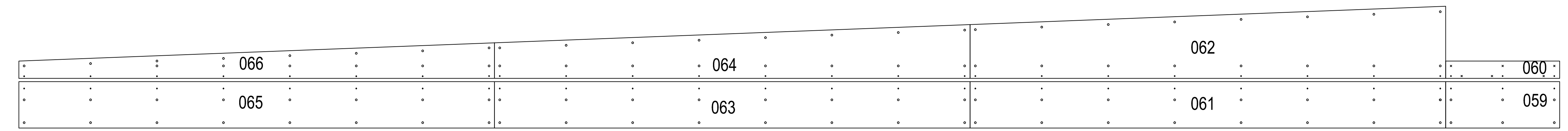
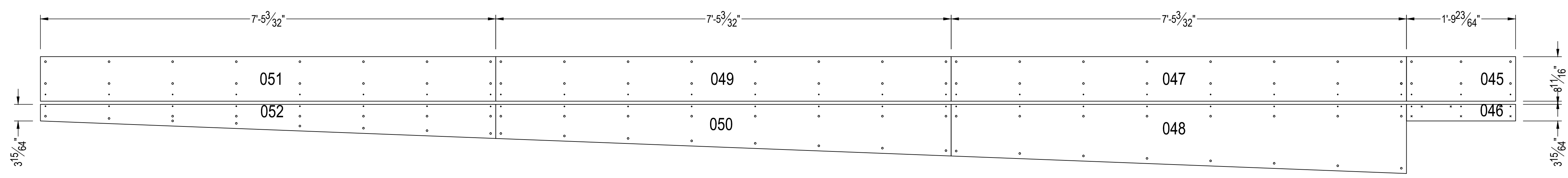

HOLES #7 / .201

$\frac{3}{16}$  TOP OF TRACK PLATES

TT-10

1 2 3 4 5 6 7 8 9 10 11 12 13 14 15 16 17 18 19 20 21 22 23 24 25 26 27 28 29 30 31 (TICKS ON 1" CENTERS)



CENTER PLATE BETWEEN  
TOP AND BOTTOM UHMW

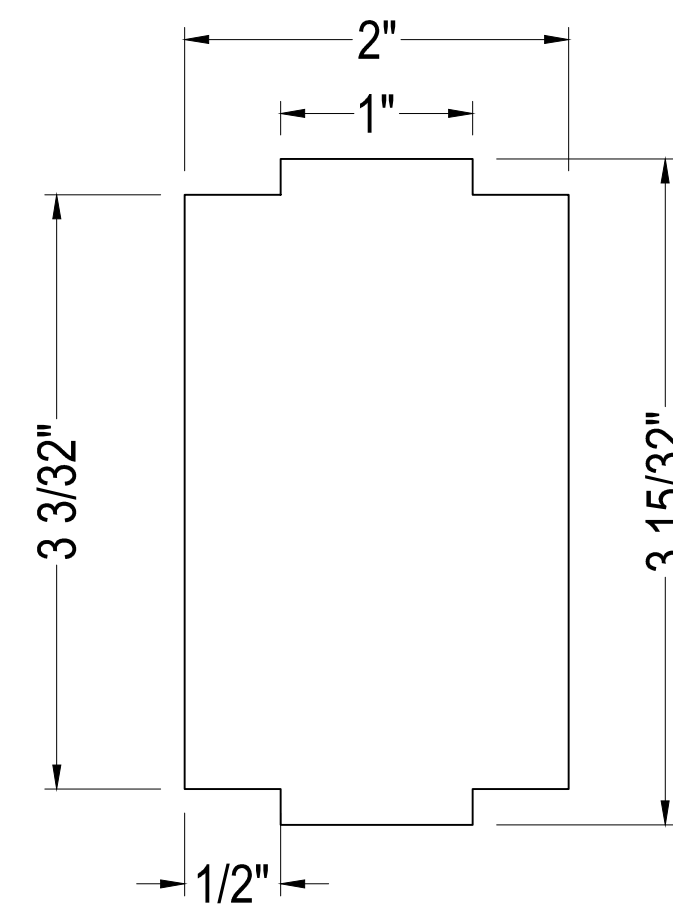

PART: 031  
QUANTITY: 88  
MATERIAL: 3/16 STEEL PLATE

TRACK UNIT TABS

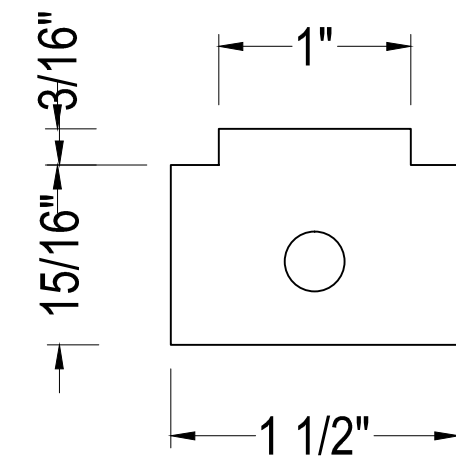

PART: 028  
QUANTITY: 88  
MATERIAL: 3/8 STEEL PLATE

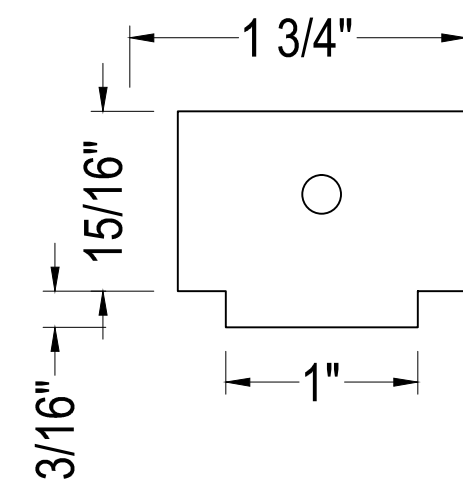

PART: 027  
QUANTITY: 88  
MATERIAL: 3/8 STEEL PLATE

TRACK UNIT TABS

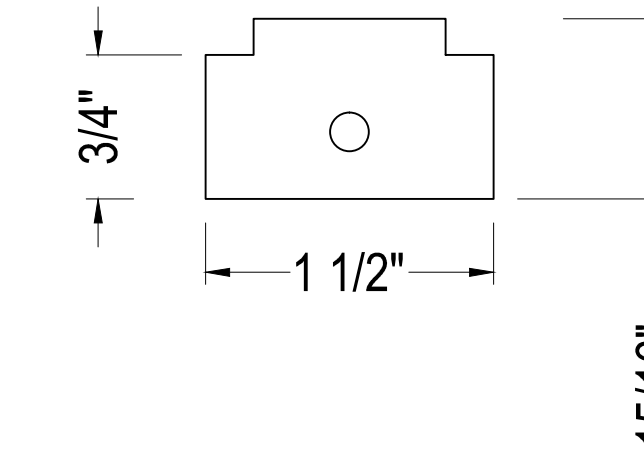

PART: 030  
QUANTITY: 88  
MATERIAL: 3/8 STEEL PLATE

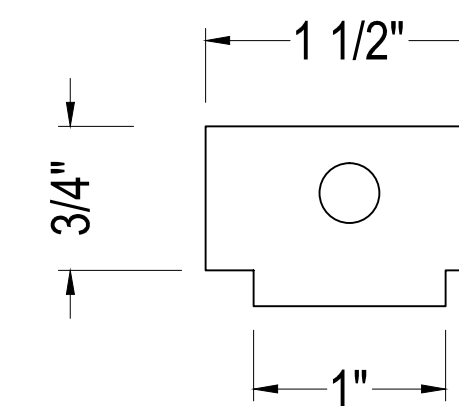

PART: 029  
QUANTITY: 88  
MATERIAL: 3/8 STEEL PLATE

TRACK ASSEMBLY TABS AND  
SPACER PLATE

TT-11

TOLERANCES UNO		GENERAL NOTES UNO	
0.x	±0.015"	INTERPRET PER PRGNW CAD STAND. STEEL WELDS PER AWS D1.1 BREAK SHARP EDGES TO R0.01" MACHINE FINISHES 125 OR BETTER	PROJECTION (US)
0.xx	±0.010"		
0.xxx	±0.005"		
FRACTION	1/32"		
ANGLE	±0.5°		

ID	DESCRIPTION	BOM	PART #	NOTE	UNIT	QUA	T. QUA
----	-------------	-----	--------	------	------	-----	--------

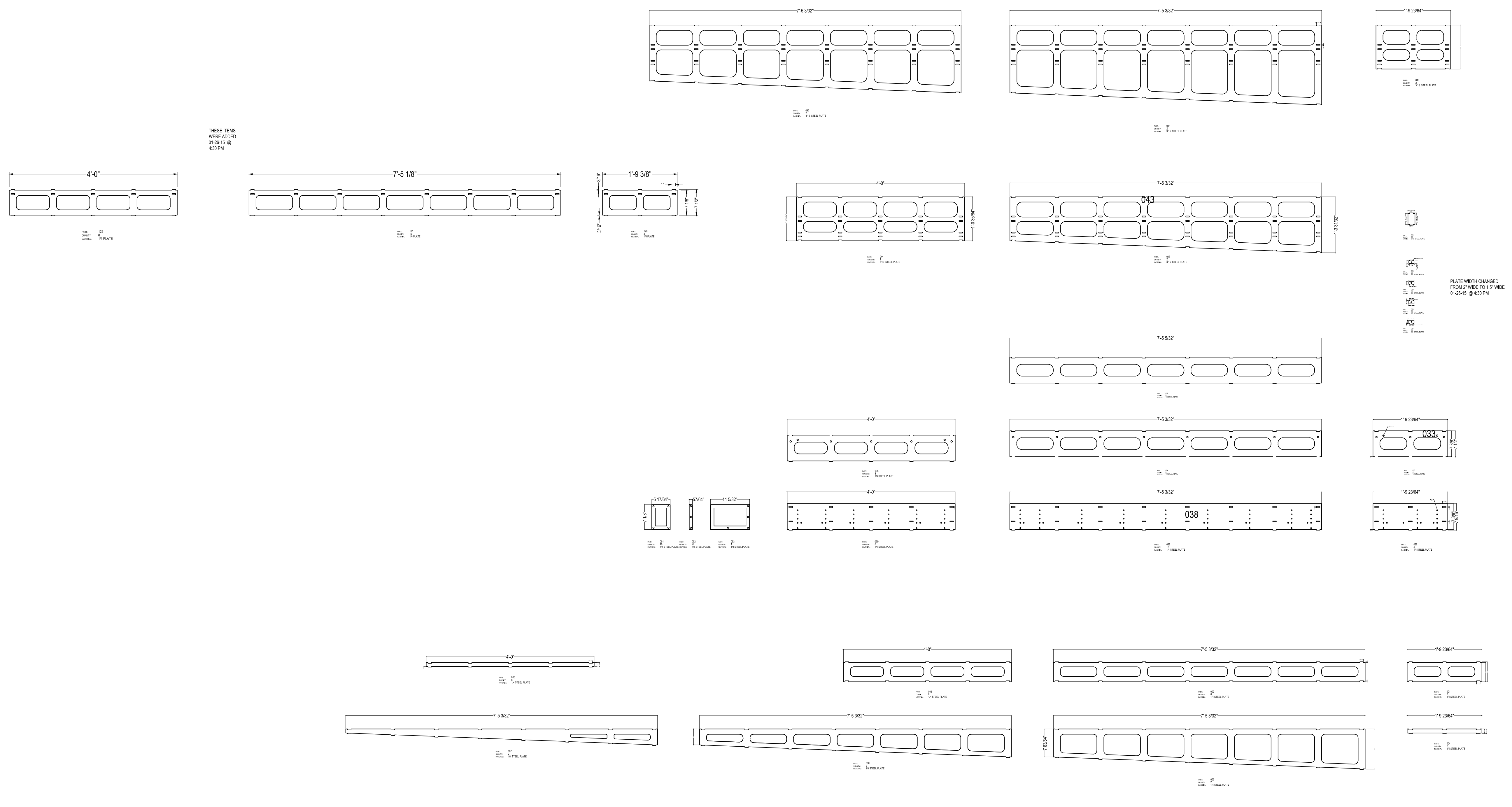

THESE ITEMS  
WERE ADDED  
01-26-15 @  
4:30 PM

PLATE WIDTH CHANGED  
FROM 15\"/>

1  
PROJECT: Doctor Zhivago  
TASK NAME: TRAIN TRACK  
ASSEMBLY: ?  
JOB: 30152-502  
TEAM LEADER: Peter Falco  
RED = CAUTION, SEE NOTE!  
GREEN = FULL SPEED

TT-02

TOLERANCES UNO		GENERAL NOTES UNO		PROJECTION (US)
0.x	±0.015"	INTERPRET PER PRGNW CAD STAND.		
0.xx	±0.010"	STEEL WELDS PER AWS D1.1		
0.xxx	±0.005"	BREAK SHARP EDGES TO R0.01"		
FRACTION	1/32"	MACHINE FINISHES 125	OR BETTER	
ANGLE	±0.5°			

ID	DESCRIPTION	BOM	PART #	NOTE	UNIT	QUA	T. QUA
----	-------------	-----	--------	------	------	-----	--------

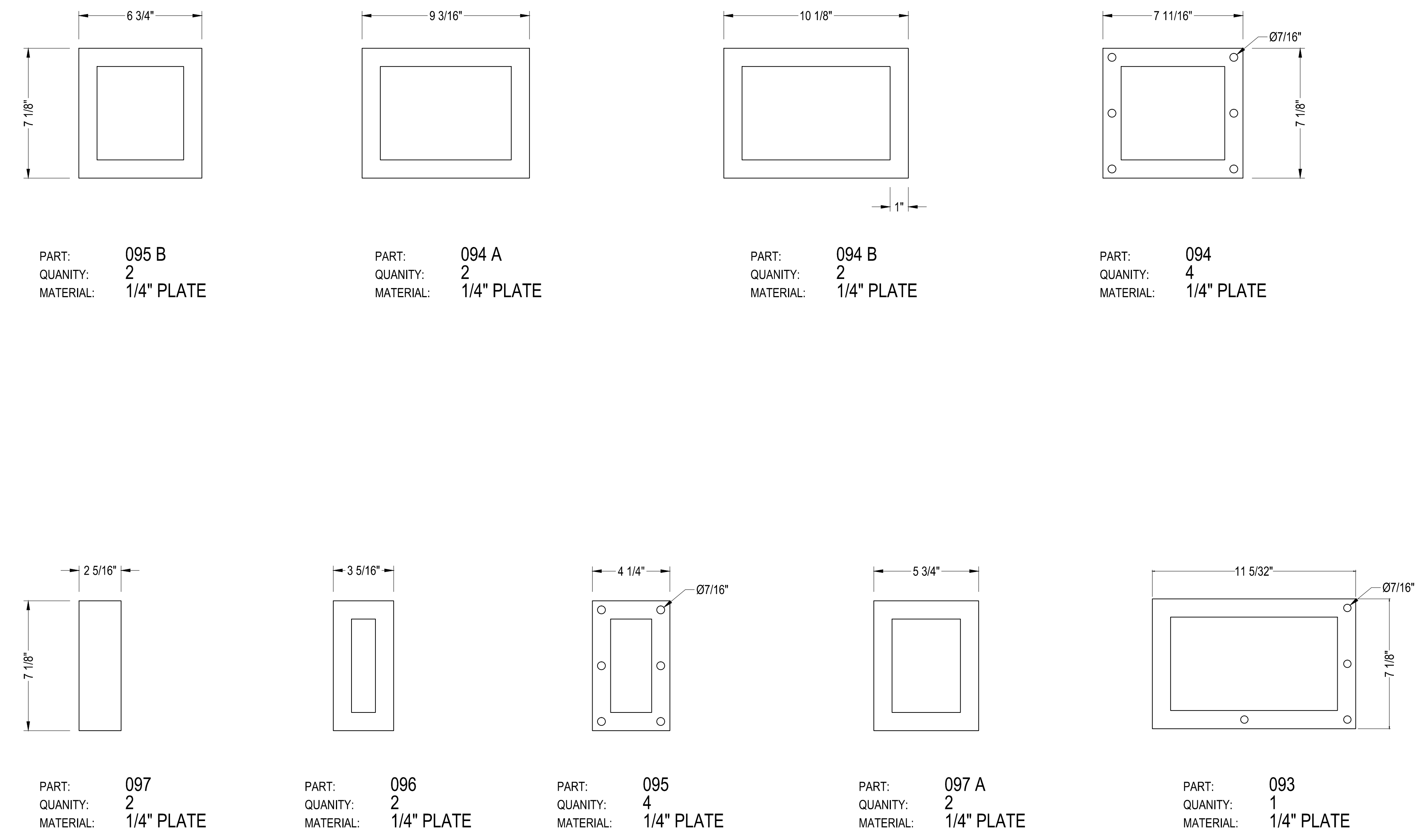

PROJECT: DOCTOR ZHIVAGO  
 TASK NAME: TRAIN TRACK  
 ASSEMBLY: ?  
 JOB#: 30153-502  
 TEAM LEADER: PETER FALCO

RED = CAUTION, SEE NOTE!!  
 GREEN = FULL SPEED

1 2 3 4 5 6 7 8 9 10 11 12 13 14 15 16 17 18 19 20 21 22 23 24 25 26 27 28 29 30 31

U  
T  
S  
R  
Q  
P  
O  
N  
M  
L  
K  
J  
I  
H  
G  
F  
E  
D  
C  
B  
A

PRG

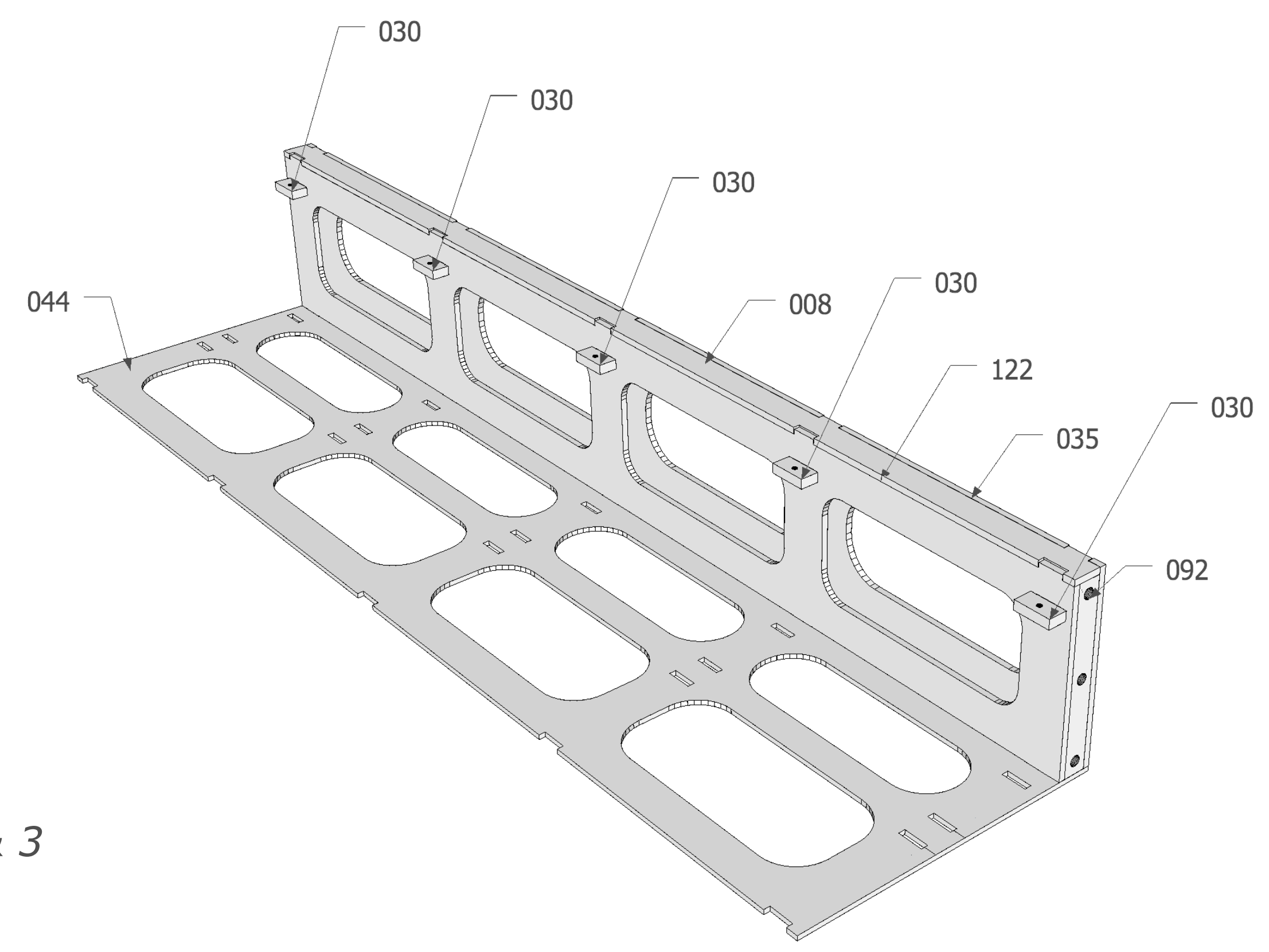
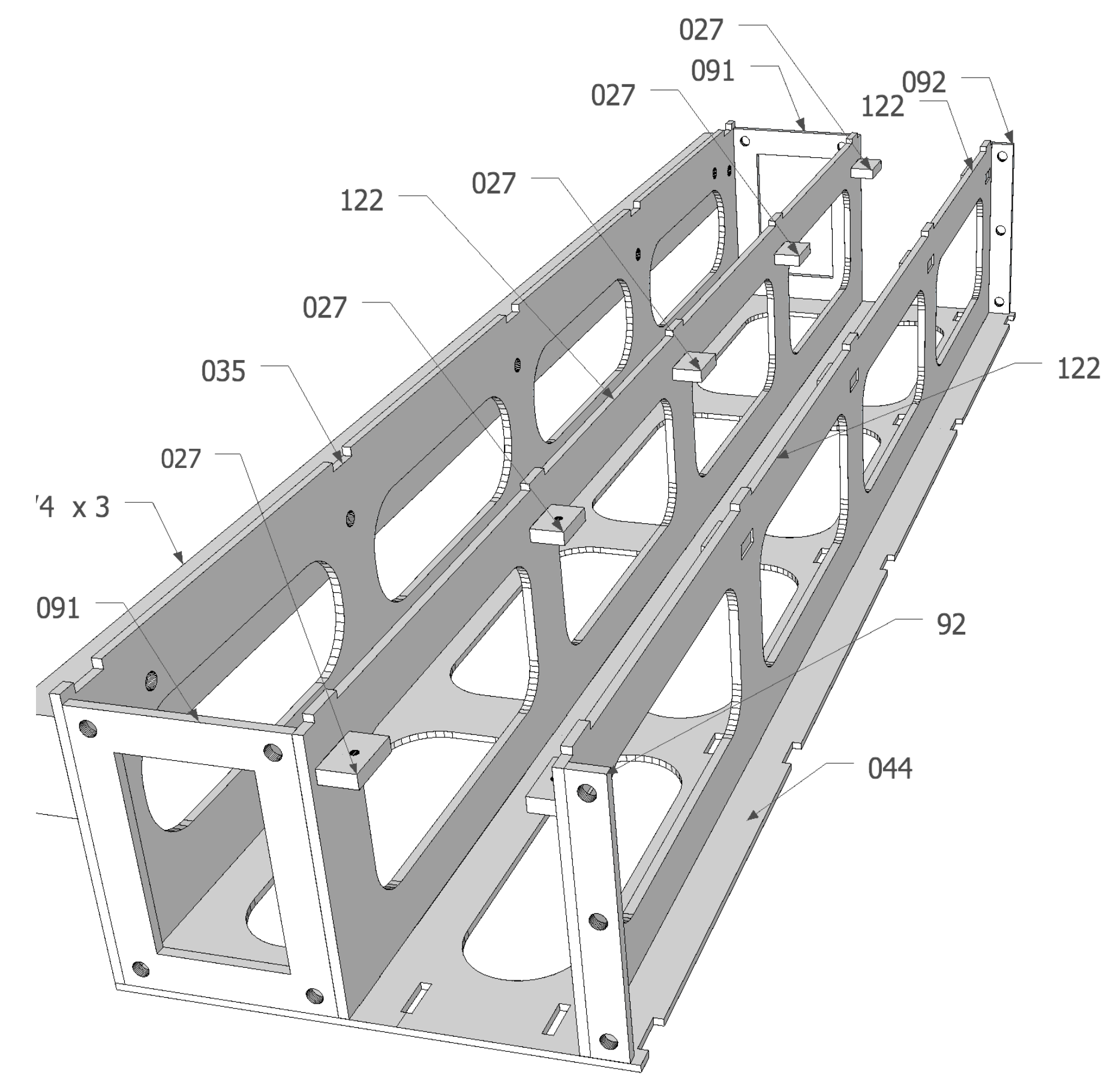

TRACK 2 & 3

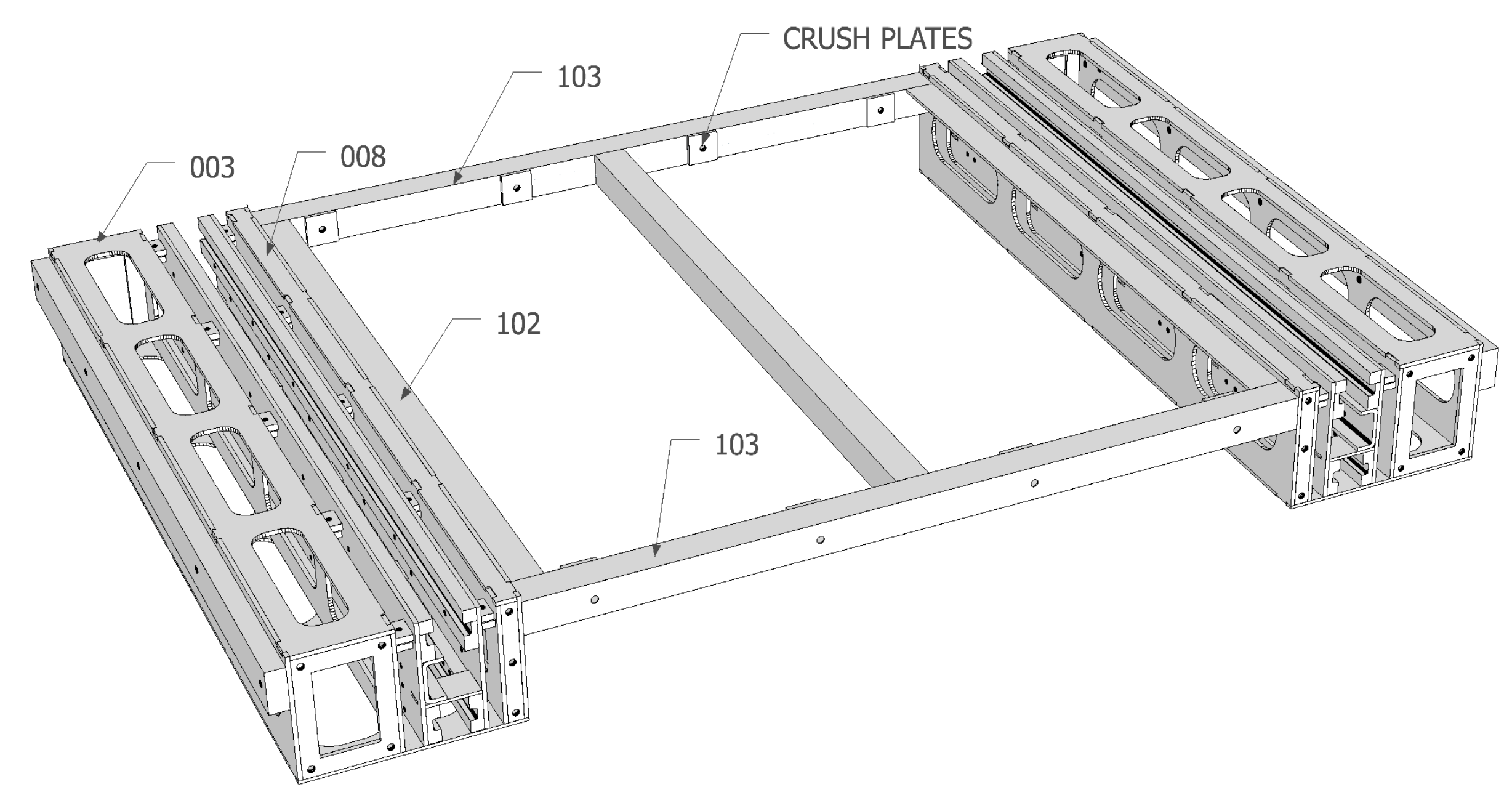
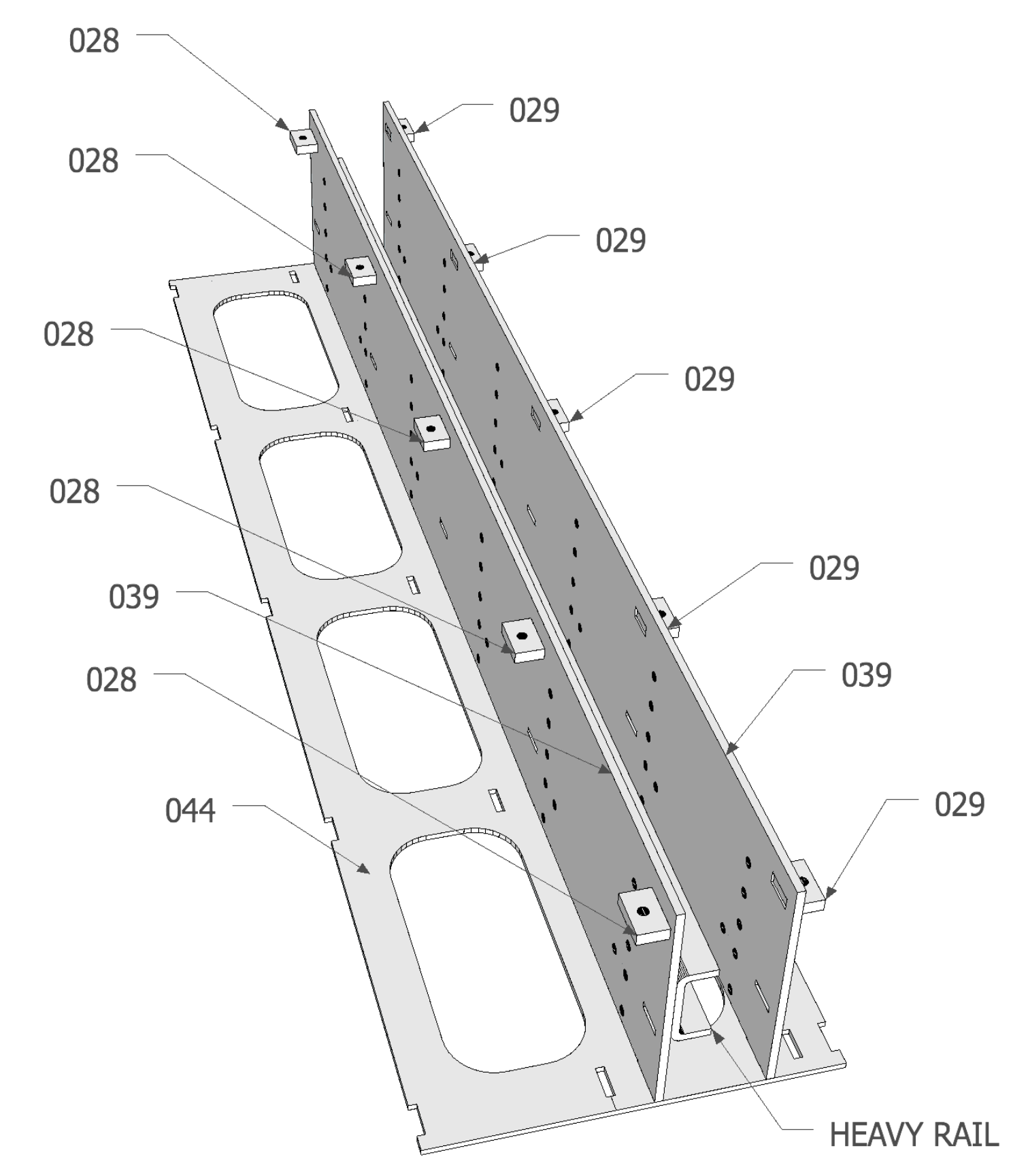

Doctor Zhivago Train Track

01

1 2 3 4 5 6 7 8 9 10 11 12 13 14 15 16 17 18 19 20 21 22 23 24 25 26 27 28 29 30 31 (TICKS ON 1" CENTERS)

1 2 3 4 5 6 7 8 9 10 11 12 13 14 15 16 17 18 19 20 21 22 23 24 25 26 27 28 29 30 31

U  
T  
S  
R  
Q  
P  
O  
N  
M  
L  
K  
J  
I  
H  
G  
F  
E  
D  
C  
B  
A

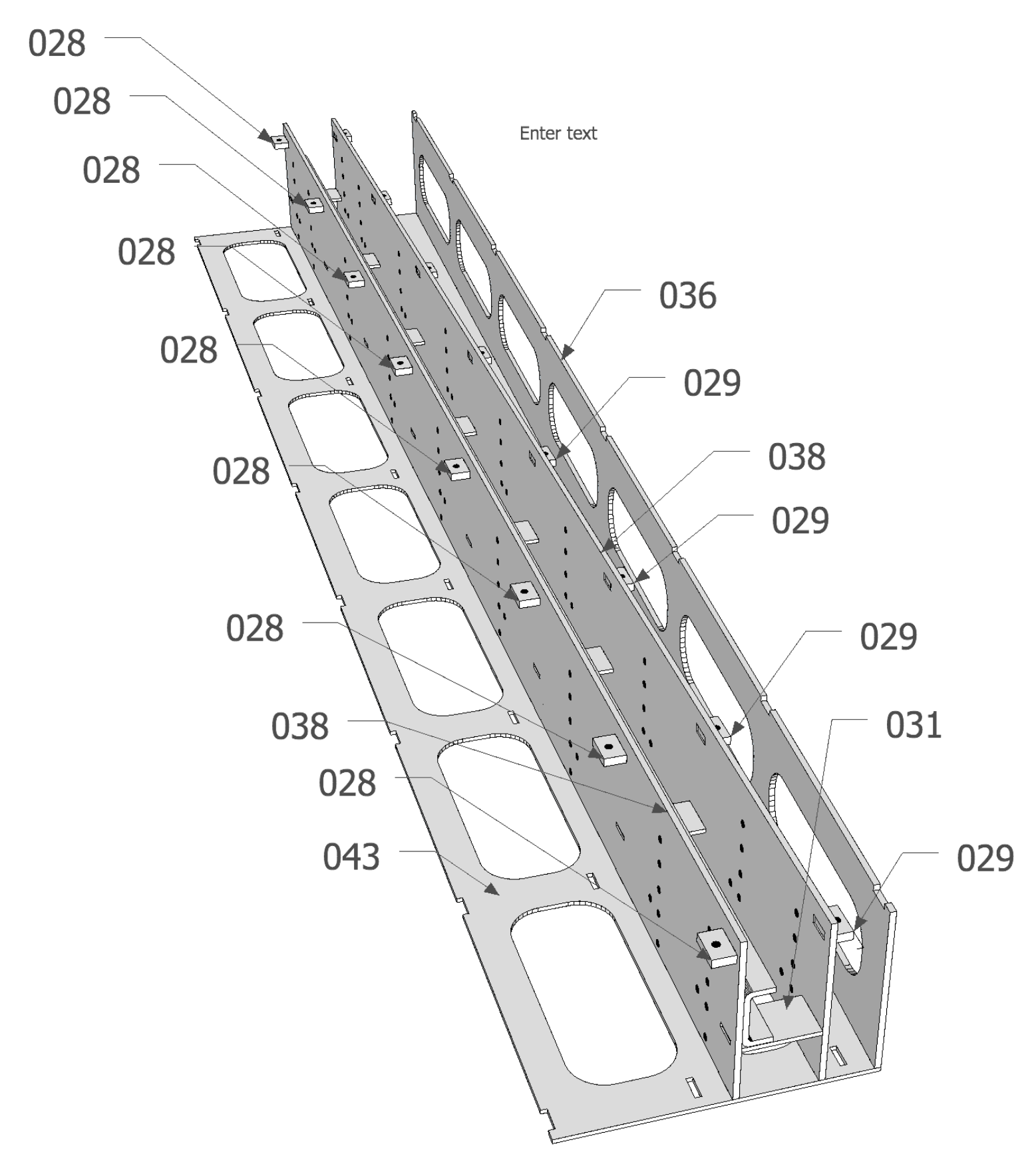
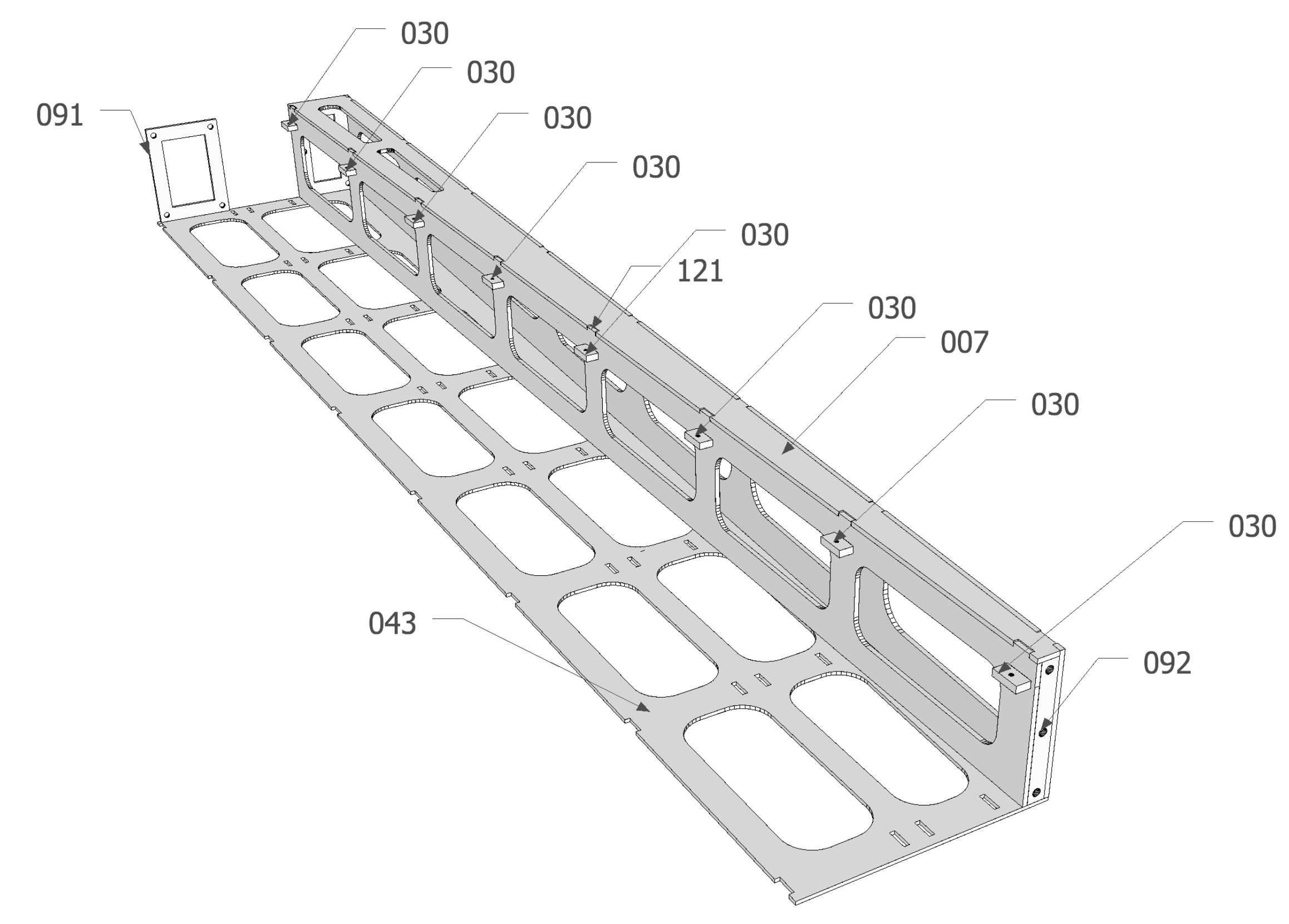
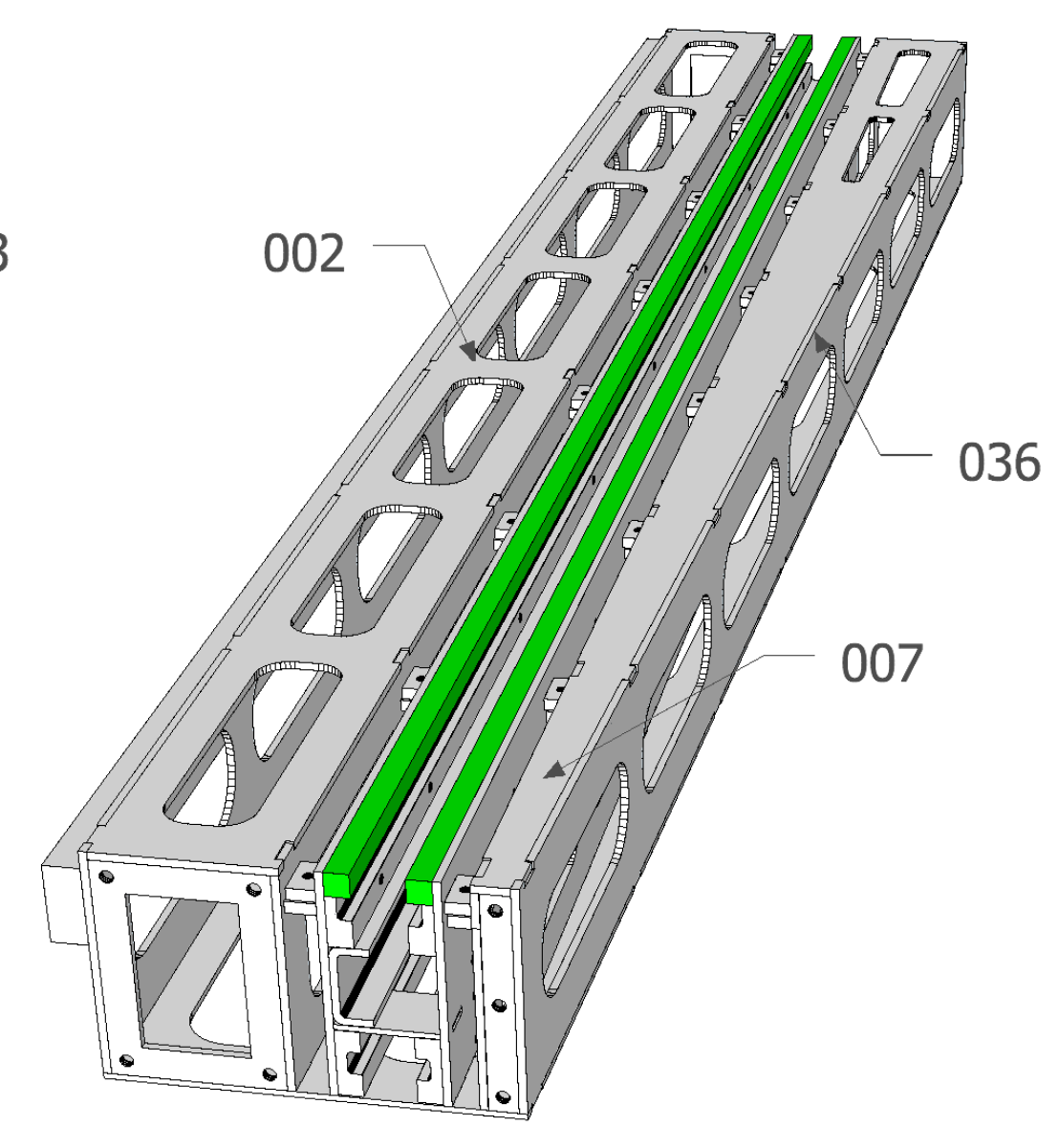
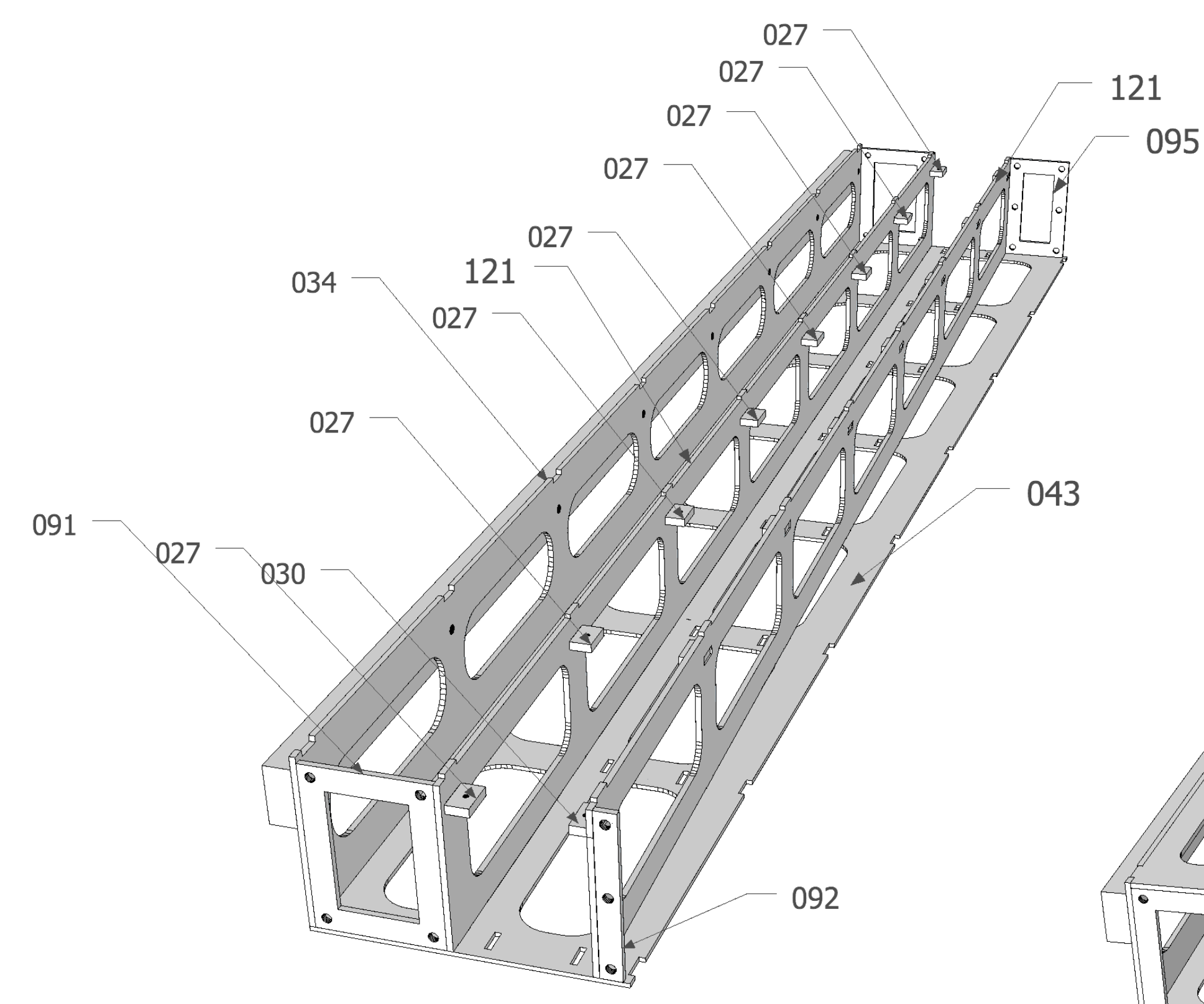

**TRACK #4**  
Enter text

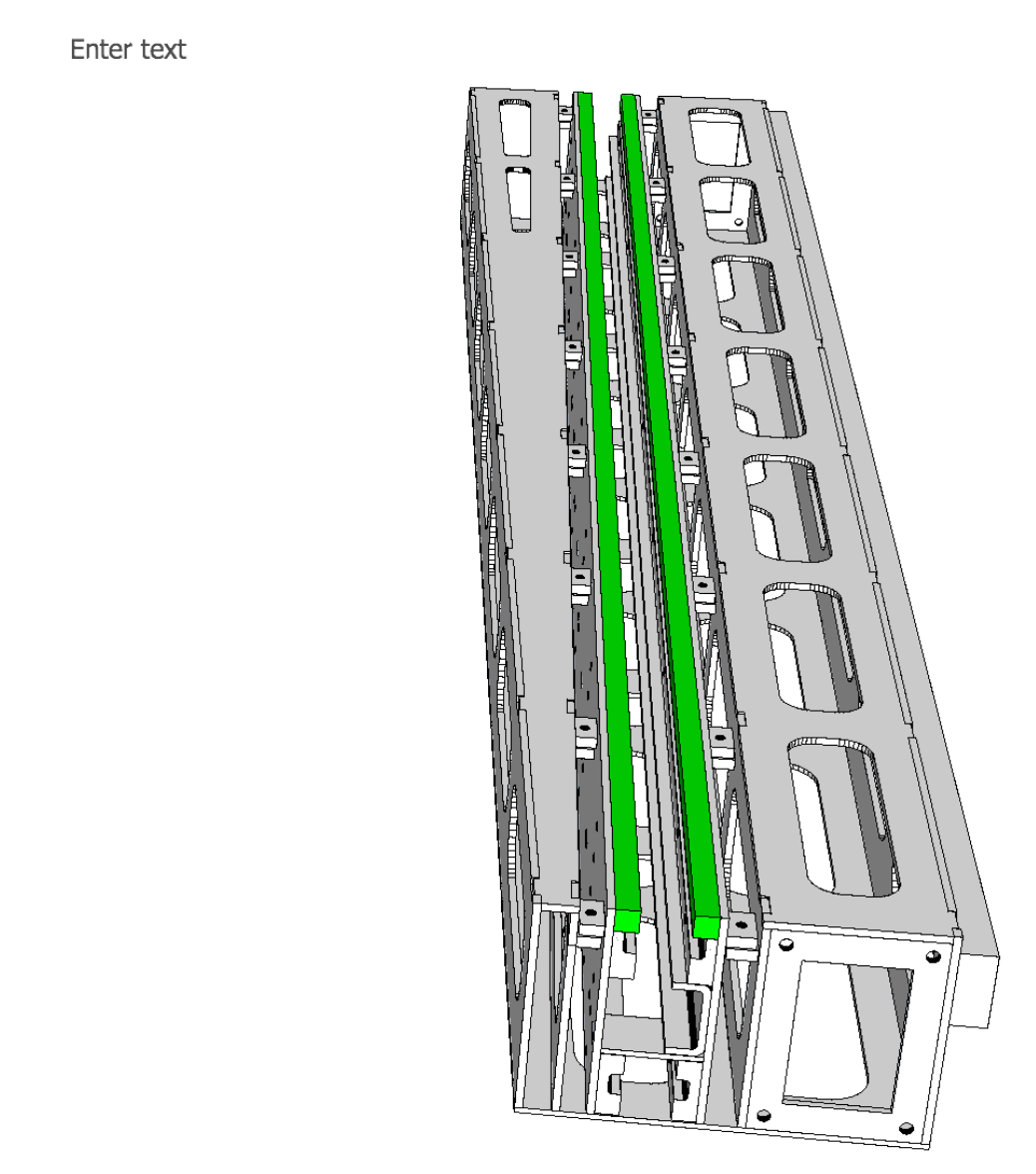
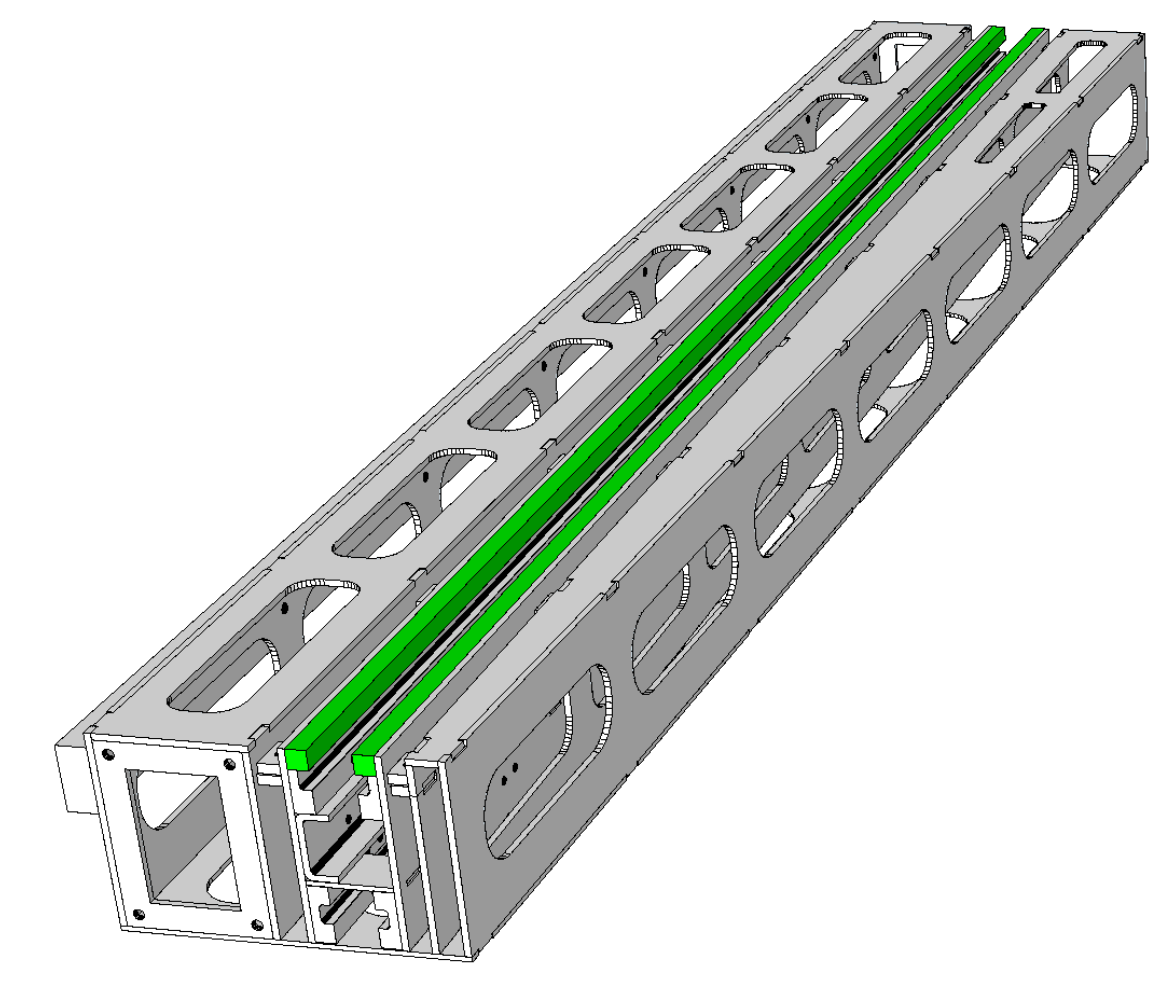

PRG=01-31-15>

DOCTOR ZHIVAGO TRAIN TRACK  
01

1 2 3 4 5 6 7 8 9 10 11 12 13 14 15 16 17 18 19 20 21 22 23 24 25 26 27 28 29 30 31 (TICKS ON 1" CENTERS)

1 2 3 4 5 6 7 8 9 10 11 12 13 14 15 16 17 18 19 20 21 22 23 24 25 26 27 28 29 30 31

U  
T  
S  
R  
Q  
P  
O  
N  
M  
L  
K  
J  
I  
H  
G  
F  
E  
D  
C  
B  
A

PRG FEB. 2, 2015

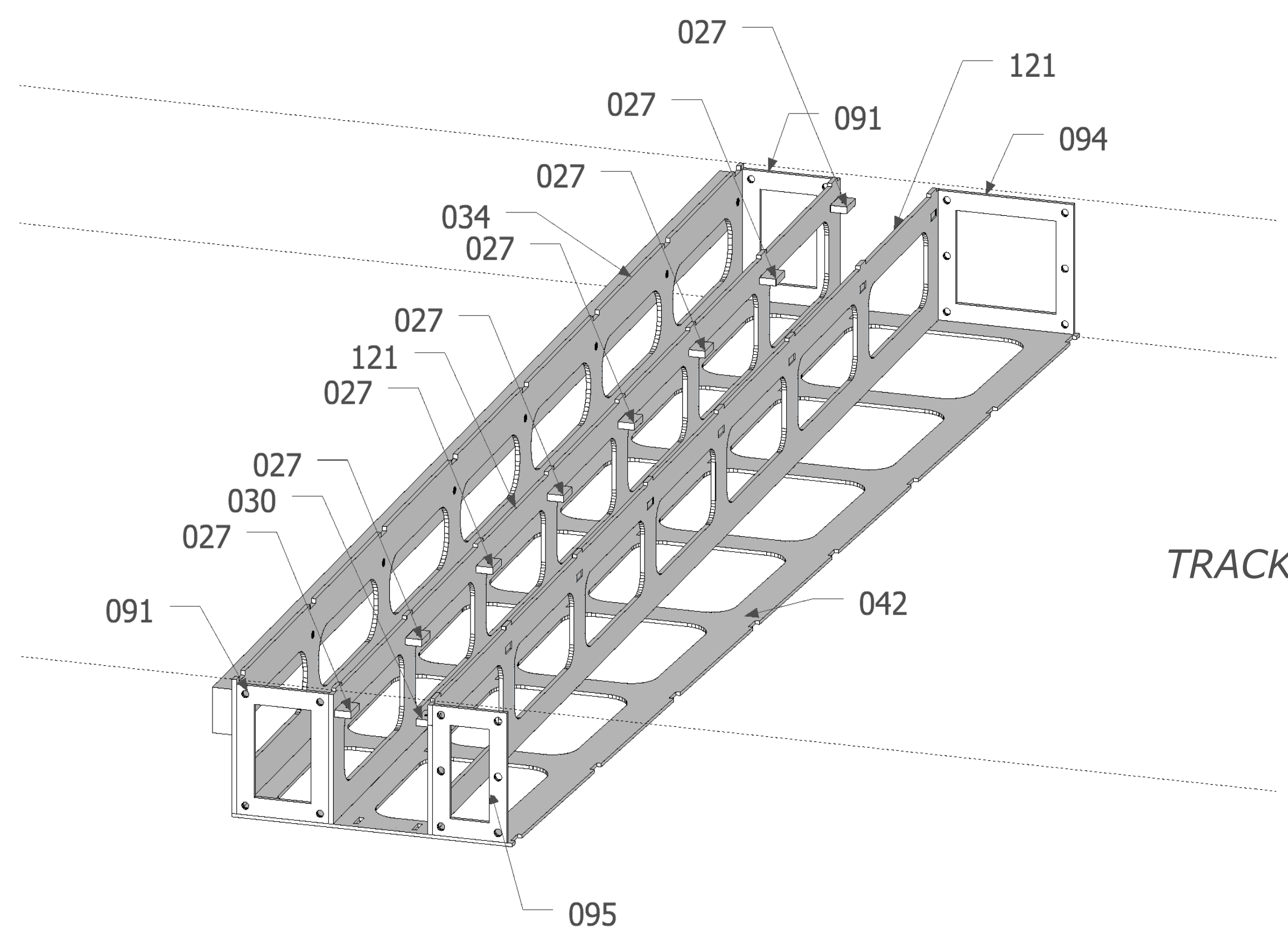

TRACK # 5

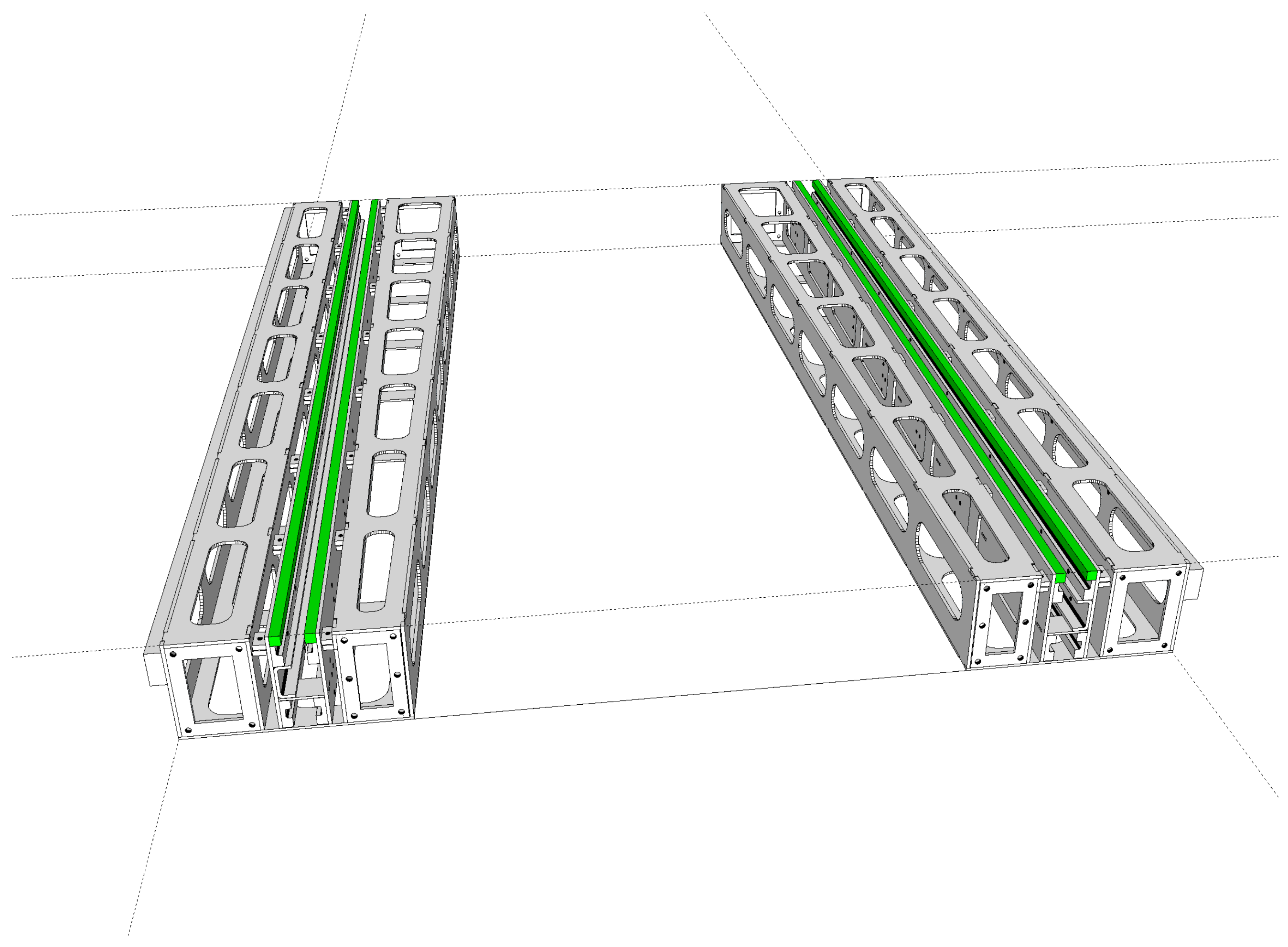
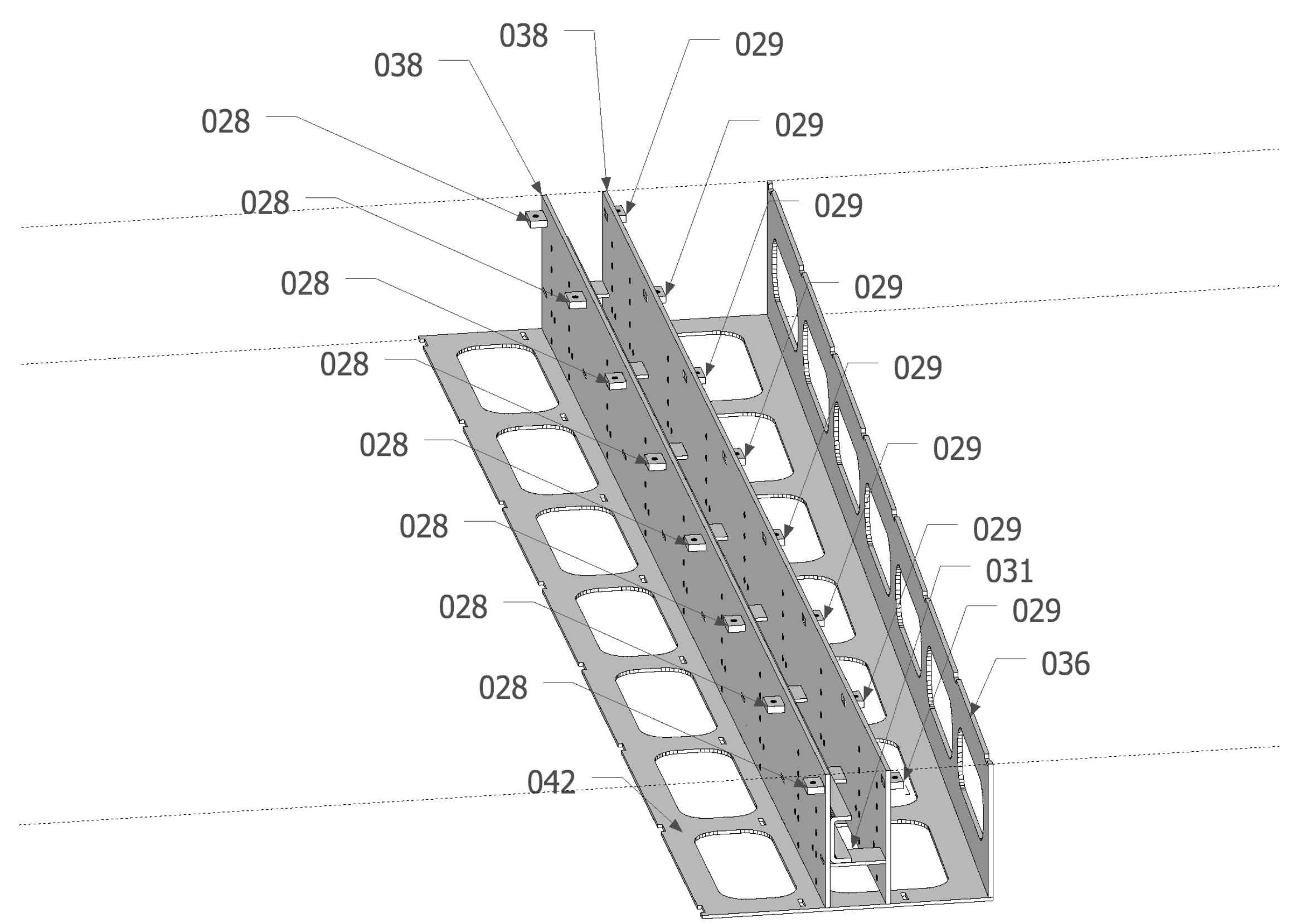
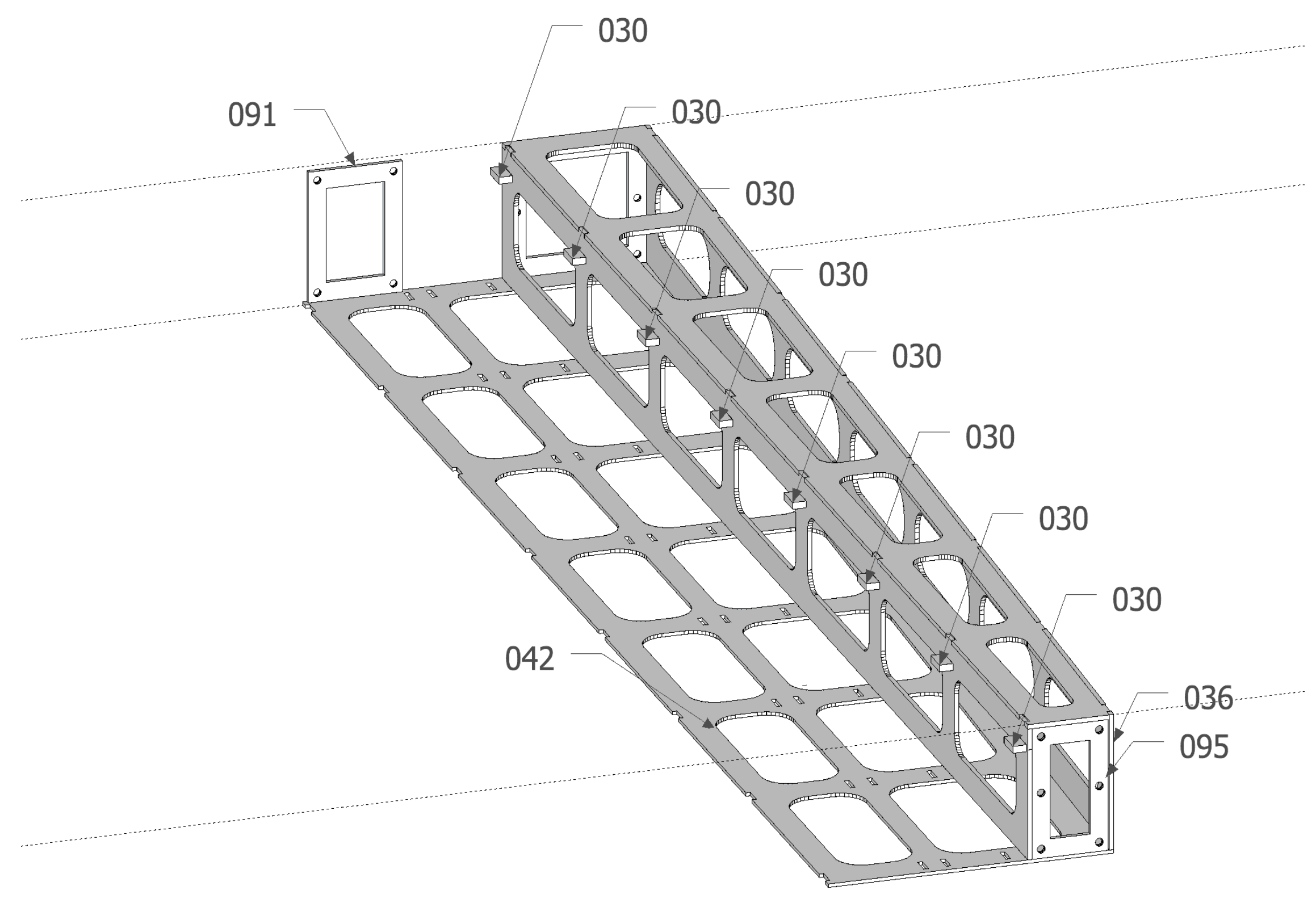

1 2 3 4 5 6 7 8 9 10 11 12 13 14 15 16 17 18 19 20 21 22 23 24 25 26 27 28 29 30 31 (TICKS ON 1" CENTERS)

DOCTOR ZHIVAGO TRAIN TRACK  
01



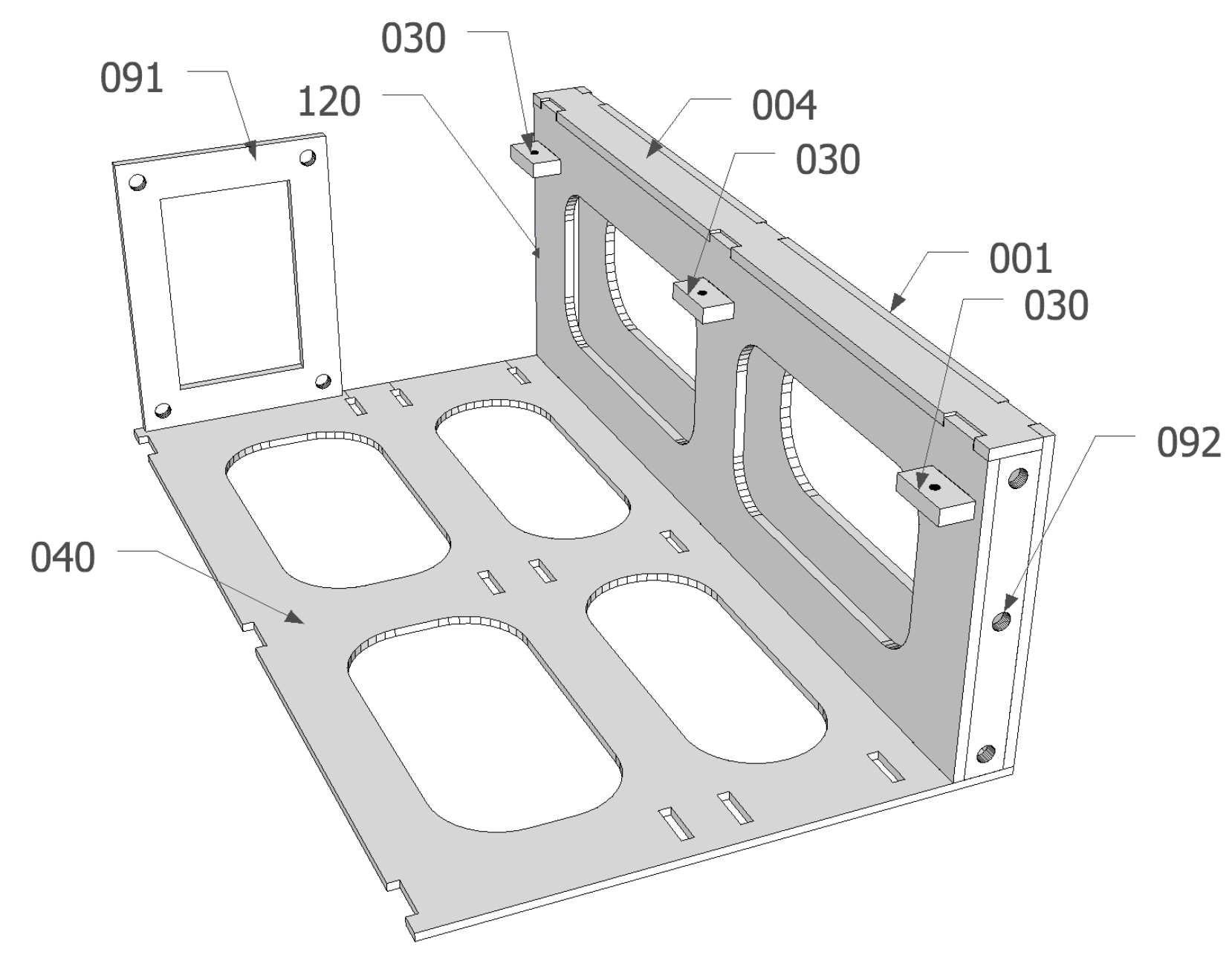
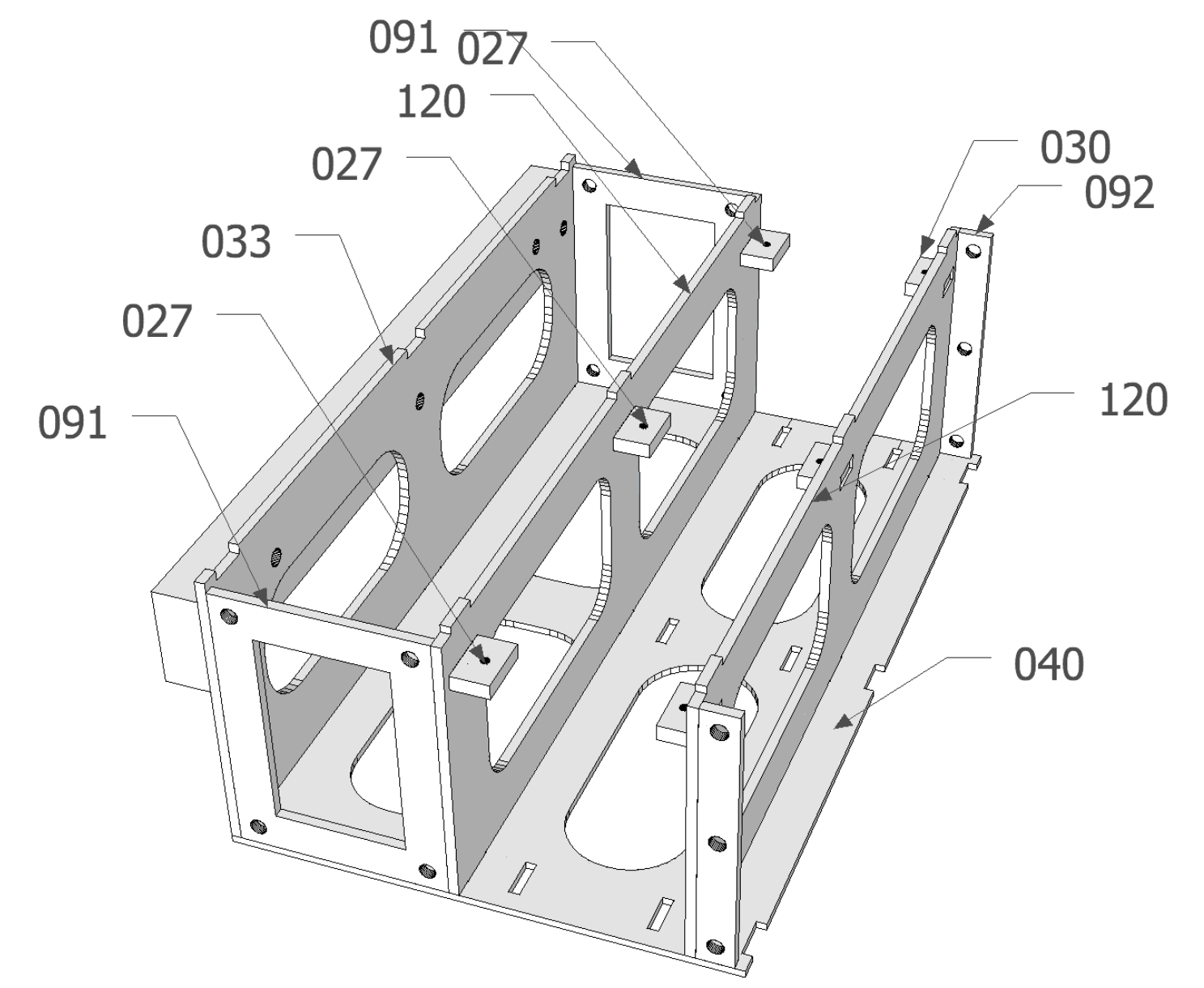

TRACK # 7

